

F L I G H T M A N U A L

for

Sailplane

Model : *Duo Discus*

Serial-No. : 95

Registr.-No. : D-9455

Date of Issue : October 1993

Pages as indicated by "LBA-app." are approved
by



Signature

LUFTFAHRT BUNDESAMT

Authority



Stamp

21 März 1994

Original date
of approval

This sailplane is to be operated in compliance
with information and limitations contained
herein.

Approval of translation has been done by best knowledge and judgement.
In any case the original text in German language is authoritative.

0.1 Record of revisions

Any revisions of the present manual, except actual weighing data, must be recorded in the following table and in the case of approved sections be endorsed by the responsible airworthiness authority.

The new or amended text in the revised page will be indicated by a black vertical line in the left hand margin, and the revision number and the date will be shown on the bottom left hand side of the page.

0.1 Erfassung der Berichtigungen / Record of revisions

| Lfd.Nr. der Berichtigung | Abschnitt | Seiten | Datum der Berichtigung | Bezug | Datum der Anerkennung durch d. LBA | Datum der Einarbeitung | Zeichen /Unterschrift |
|--------------------------|------------------|----------------------------------|--------------------------|-------------------------------|--|------------------------|-----------------------|
| Revision No. | Affected section | Affected pages | Date of issue | Reference | Date of Approval by LBA | Date of Insertion | Signature |
| 1 | 0 | 0.2.8 | | | | | |
| | 7 | 7.2.1 7.2.7 | April 1994 April 1994 | HB 396-2 HB 396-2 | | | |
| 2 | 0 | 0.2.5 | | | | | |
| | 4 | 4.2.2 | April 1994 | HB 396-3 | | | |
| 3 | 0 | 0.2.5 | | | | | |
| | 4 | 4.5.3.1 | Dezember 1994 | FAA | | | |
| 4 | 0 | 0.1.2 0.2.5 0.2.6 0.2.8 | | | | | |
| | 4 | 4.3.3 | Feb 96 | TM 396-3 und/ and NB 396-7 | 22.02.96  | | |
| | | 4.3.4 | Feb 96 | " " | | | |
| | | 4.5.1.2 | Feb 96 | " " | | | |
| | | 4.5.3.3 | Feb 96 | " " | | | |
| | 5 | 5.2.1 | Feb 96 | " " | | | |
| | | 5.2.2 | Feb 96 | " " | | | |
| | | 5.3.2.1 | Feb 96 | " " | | | |
| | | 5.3.2.2 | Feb 96 | " " | | | |
| | 7 | 7.3.2 | Feb 96 | " " | | | |
| 7.6 | | Feb 96 | " " | | | | |

NB: Modification Bulletin - Änderungsblatt
 TN: Technical Note - Technische Mitteilung

0.1 Erfassung der Berichtigungen / Records of revisions

| Lfd. Nr. der Berichtigung | Abschnitt | Seiten | Datum der Berichtigung | Bezug | Datum der Anerkennung durch das LBA | Datum der Ein- arbeitung | Zeichen /Unter- schrift |
|---------------------------|---------------------|---|------------------------|--|-------------------------------------|--------------------------|-------------------------|
| Revision No. | Affected section | Affected page | Date of issue | Reference | Date of Approval by LBA | Date of Insertion | Signature |
| 5 | 0 2 4 | 0.2.1 0.2.3 0.2.5 2.2 2.13 2.15 4.5.1.1 | January 2000 | TN 396-5/ MB 396-10 Höchstzul. Flugzeug- schleppgeschwindigkeit. Werk-Nr. 1, 8 bis 244 wahlweise, Serie ab 245 Max. permitted aero tow speed S/N 1, 8 8 through 244 option. std. on S/N 245 and up | | | |
| 6 | 0 4 | 0.2.5 4.2.2 | June 2001 | AB 396-3 Ansteckflügel Werk-Nr. 16 und ab 18 MB 396-3 Outboard wing panels S/N 16 and and S/N 18 and up | | | |
| 7 | 0 7 | 0.2.8 7.2.1 7.2.7 7.3.1 | February 2004 | AB 396-14 (Haubenscharnier Hebel vorn ab S/N 422 MB 396-14 (canopy hinge, lever front S/N 422 and up) | | | |
| 8 | 4 7 | 4.4 7.2.4 | August 2004 | TM-Nr. 396-10 (herausnehmbarer hinterer Steuerknüppel, wahlweise alle Werk- Nr.) TN-Nr. 396-10 (removable aft stick, optional all S/N) | | | |
| 9 | 0 8 | 0.2.1 0.2.9 8.3 | Juni 2005 | Ergänzungen Supplements | | | |

MB: Modification Bulletin – Änderungsblatt
 TN : Technical Note – Technische Mitteilung

0.1 Erfassung der Berichtigungen / Records of revisions

| Lfd. Nr. der Berichtigung | Abschnitt | Seiten | Datum der Berichtigung | Bezug | Datum der Anerkennung durch das LBA | Datum der Ein- arbeitung | Zeichen /Unter- schrift |
|---------------------------|---------------------------------|---|------------------------|--|-------------------------------------|--------------------------|-------------------------|
| Revision No. | Affected section | Affected page | Date of issue | Reference | Date of Approval by LBA | Date of Insertion | Signature |
| 10 | 0 4 | 0.2.1 4.5.1.2 | July 2005 | TM 396-11 F-Schlepp mit Motor- segler, wahlweise Werk-Nr. 1 bis 471 TN 396-11 Aerotow with powered sailplane, optional S/N 1 through 471 | | | |
| 11 | 0 1 2 4 5 6 7 | Deckblatt cover sheet 0.2.1 0.2.2 0.2.3 0.2.5 0.2.6 0.2.7 0.2.8 1.2 1.4.1 1.5 2.3 2.15 4.3.1 4.3.2 4.5.1.2 4.5.3.1 4.5.3.3 4.5.3.4 4.5.4 4.5.5 5.2.2 5.3.2.1 5.3.2.2 6.2.3 6.2.7 7.2.1 *) 7.2.4 7.2.7 *) 7.3.1*) 7.7 *) entfällt bei Werk-Nr. 469 not applicable for S/N 469 | September 2005 | ÄB 396-15 Winglets, Hinterkanten- klappen (Werk-Nr. 469) und gefedertes Fahrwerk (Werk-Nr. 450 und ab Werk-Nr. 473) MB 396-15 Winglets, trailing edge flap (S/N 469) and landing gear with shock absorber struts (S/N 450, 473 and on) | | | |

MB: Modification Bulletin – Änderungsblatt
TN : Technical Note – Technische Mitteilung

0.1 Erfassung der Berichtigungen / Records of revisions

| Lfd. Nr. der Berichtigung | Abschnitt | Seiten | Datum der Berichtigung | Bezug | Datum der Anerkennung durch das LBA | Datum der Ein- ar- beitung | Zeichen /Unter- schrift |
|---------------------------|---------------------------------|--|------------------------|--|-------------------------------------|----------------------------|-------------------------|
| Revision No. | Affected section | Affected page | Date of issue | Reference | Date of Approval by LBA | Date of Insertion | Signature |
| 12 | 0 1 4 5 | 0.2.1 0.2.2 0.2.5 0.2.6 1.4.1 1.5 4.3.1 4.5.3.1 4.5.3.3 4.5.3.4 4.5.4 5.3.2.1 5.3.2.2 | November 2005 | <u>TM 396-12</u> Winglets wahlweise Werk-Nr. 1 bis 446, 452 bis 468 und 471 <u>TN 396-12</u> winglets, optional S/N 1 through 446, 452 through 468 and 471 | | | |
| 13 | 0 1 | 0.2.2 1.4.1 | Juli 2006 July 2006 | <u>Ergänzungen zum AB-Nr. 396-15</u> ab Werk-Nr. 511 Tragflügel in GFK/CFK <u>Supplement to MB-No. 396-15</u> S/N 511 and up Wings in GFK/CFK | | | |
| 14 | 0 1 2 3 4 5 6 | 0.2.2 0.2.3 0.2.4 0.2.5 0.2.6 0.2.7 1.4.3 2.6 2.10 2.13 2.15 3.5 4.5.1.2 4.5.1.4 4.5.4 5.2.2 6.2.1 6.2.5 6.2.6 | Juni 2007 June 2007 | <u>Ergänzungen zum AB-Nr. 396-15</u> ab Werk-Nr. 537 <u>TM-Nr. 396-13</u> Werk-Nr. 511 bis 536 Erhöhung der max. Flug- masse auf 750 kg <u>Supplement to MB-No. 396-15</u> S/N 537 and up <u>TN-No. 396-13</u> SN 511 through 536 optional Increase of the max. take-off mass to 750 kg | | | |

MB: Modification Bulletin – Änderungsblatt
TN : Technical Note – Technische Mitteilung

0.1 Erfassung der Berichtigungen / Records of revisions

| Lfd. Nr. der Berichtigung | Abschnitt | Seiten | Datum der Berichtigung | Bezug | Datum der Anerkennung durch das LBA | Datum der Ein- arbeitung | Zeichen /Unter- schrift |
|---------------------------|---------------------------------------|---|----------------------------|--|-------------------------------------|--------------------------|-------------------------|
| Revision No. | Affected section | Affected page | Date of issue | Reference | Date of Approval by LBA | Date of Insertion | Signature |
| 15 | 0 9 | 0.2.10 9.2 9.4 | Juni 2007 June 2007 | <u>TM 396-15</u> Nasenschleifsporn wahlweise Alle Werk-Nr. <u>TN 396-15</u> Nose skid optional All S/N | | | |
| 16 | 1 2 4 6 7 | 1.4.1 1.4.3*) 1.5 2.10 2.15 4.3.1*) 4.3.4*) 6.2.1 6.2.2*) 6.2.3 6.2.6 6.2.7 7.2.1 7.2.4 7.2.5*) 7.2.7 7.3.1 7.3.2 7.9.2*) 7.9.3*) 7.12.1*) 7.12.2 7.12.3*) *) nur bei Verwendung des Rumpfes nach AB-Nr. 396-16 (xL) only use for „xL“ fuselage (MB-No. 396-16) | Februar 2008 | <u>TM 396-16</u> Optionale Verwendung der Segelflugzeug-Rümpfe nach dem AB-Nr. 396-15 (Duo x) oder AB-Nr. 396-16 (Duo xL) (Werk-Nr. 1 bis 533 und 535 bis 541) <u>TN 396-16</u> Optional use of fuselages according to MB-No. 396-15 (Duo x) or MB-No. 396-16 (Duo xL) SN 1 through 533 and 535 through 541 | | | |

MB: Modification Bulletin – Änderungsblatt
 TN : Technical Note – Technische Mitteilung

0.2 Verzeichnis der Seiten / List of effective pages

| Abschnitt | Seite | Ausgabe-Datum | Bezug |
|-----------|--------|---------------|-------|
| 0 | 0.1.1 | | |
| | 0.1.2 | | |
| | 0.1.3 | | |
| | 0.1.4 | | |
| | 0.1.5 | | |
| | 0.1.6 | | |
| | 0.2.1 | | |
| | 0.2.2 | | |
| | 0.2.3 | | |
| | 0.2.4 | | |
| | 0.2.5 | | |
| | 0.2.6 | | |
| | 0.2.7 | | |
| | 0.2.8 | | |
| | 0.2.9 | | |
| | 0.2.10 | | |
| | 0.3.1 | | |

0.2 Verzeichnis der Seiten / List of effective pages

| Ab-schnitt | Seite | Ausgabe-datum | Bezug |
|------------|-------|---------------|-------|
| 1 | 1.1.1 | Okt. 1993 | |
| | 1.1.2 | Okt. 1993 | |
| | 1.2 | Okt. 1993 | |
| | 1.3 | Okt. 1993 | |
| | 1.4.1 | Okt. 1993 | |
| | 1.4.2 | Okt. 1993 | |
| | 1.4.3 | Okt. 1993 | |
| | 1.5 | Okt. 1993 | |

0.2 Verzeichnis der Seiten / List of effective pages

| Ab-schnitt | Seite | Ausgabe-datum | Bezug |
|---------------|---------------|-------------------------|-------------------------|
| 2 | 2.1.1 | Okt. 1993 | |
| | 2.1.2 | Okt. 1993 | |
| | LBA-ank. 2.2 | Jan. 2000 | TN 396-5 / MB 396-10 |
| | LBA-ank. 2.3 | Okt. 1993 | |
| | LBA-ank. 2.4 | Okt. 1993 | |
| | LBA-ank. 2.5 | Okt. 1993 | |
| | LBA-ank. 2.6 | Okt. 1993 | |
| | LBA-ank. 2.7 | Okt. 1993 | |
| | LBA-ank. 2.8 | Okt. 1993 | |
| | LBA-ank. 2.9 | Okt. 1993 | |
| | LBA-ank. 2.10 | Okt. 1993 | |
| | LBA-ank. 2.11 | Okt. 1993 | |
| | LBA-ank. 2.12 | Okt. 1993 | |
| | LBA-ank. 2.13 | Jan. 2000 | TN 396-5 / MB 396-10 |
| | LBA-ank. 2.14 | Okt. 1993 | |
| LBA-ank. 2.15 | Jan. 2000 | TN 396-5 / MB 396-10 | |

0.2 Verzeichnis der Seiten / List of effective pages

| Ab-schnitt | Seite | Ausgabe-datum | Bezug |
|------------|----------------|---------------|-------|
| 3 | 3.1.1 | Okt. 1993 | |
| | 3.1.2 | Okt. 1993 | |
| | LBA-ank. 3.2 | Okt. 1993 | |
| | LBA-ank. 3.3 | Okt. 1993 | |
| | LBA-ank. 3.4 | Okt. 1993 | |
| | LBA-ank. 3.5 | Okt. 1993 | |
| | LBA-ank. 3.6 | Okt. 1993 | |
| | LBA-ank. 3.7 | Okt. 1993 | |
| | LBA-ank. 3.8 | Okt. 1993 | |
| | LBA-ank. 3.9.1 | Okt. 1993 | |
| | LBA-ank. 3.9.2 | Okt. 1993 | |

0.2 Verzeichnis der Seiten / List of effective pages

| Abschnitt Affected section | Seite Affected pages | Ausgabe-Datum Date of issue | Bezug Reference |
|-------------------------------|-------------------------|--------------------------------|--------------------------------|
| 4 | 4.1.1 | Okt. 1993 | |
| | 4.1.2 | Okt. 1993 | |
| | LBA-ank. 4.2.1 | Okt. 1993 | |
| | LBA-ank. 4.2.2 | Juni 2001 | MB 396-3 |
| | LBA-ank. 4.2.3 | Okt. 1993 | |
| | LBA-ank. 4.3.1 | Okt. 1993 | |
| | LBA-ank. 4.3.2 | Okt. 1993 | |
| | LBA-ank. 4.3.3 | Febr. 1996 | TM 396-3 / MB 396-7 |
| | LBA-ank. 4.3.4 | Febr. 1996 | TM 396-3 / MB 396-7 |
| | LBA-ank. 4.4 | August 2004 | TM 396-10 |
| | LBA-ank. 4.5.1.1 | Jan. 2000 | TM 396-5 / MB 396-10 |
| | LBA-ank. 4.5.1.2 | Juli 2005 | TM 396-3 / MB 396-7, TN 396-11 |
| | LBA-ank. 4.5.1.3 | Okt. 1993 | |
| | LBA-ank. 4.5.1.4 | Okt. 1993 | |
| | LBA-ank. 4.5.2 | Okt. 1993 | |
| | LBA-ank. 4.5.3.1 | Dez. 1994 | FAA |
| | LBA-ank. 4.5.3.2 | Okt. 1993 | |
| | LBA-ank. 4.5.3.3 | Febr. 1996 | TM 396-3 / MB 396-7 |
| | LBA-ank. 4.5.3.4 | Okt. 1993 | |
| | LBA-ank. 4.5.4 | Okt. 1993 | |
| | LBA-ank. 4.5.5 | Okt. 1993 | |
| | LBA-ank. 4.5.6.1 | Okt. 1993 | |
| | LBA-ank. 4.5.6.2 | Okt. 1993 | |
| | LBA-ank. 4.5.6.3 | Okt. 1993 | |
| | LBA-ank. 4.5.6.4 | Okt. 1993 | |
| | LBA-ank. 4.5.6.5 | Okt. 1993 | |
| | LBA-ank. 4.5.7.1 | Okt. 1993 | |
| | LBA-ank. 4.5.7.2 | Okt. 1993 | |
| | LBA-ank. 4.5.8 | Okt. 1993 | |
| | LBA-ank. 4.5.9 | Okt. 1993 | |

0.2 Verzeichnis der Seiten / List of effective pages

| Ab-schnitt | Seite | Ausgabe-datum | Bezug |
|------------|-------------------|---------------|-----------------|
| 5 | 5.1.1 | Okt. 1993 | |
| | 5.1.2 | Okt. 1993 | |
| | LBA-ankerk. 5.2.1 | Feb. 1996 | TM396-3/MB396-7 |
| | LBA-ankerk. 5.2.2 | Feb. 1996 | TM396-3/MB396-7 |
| | LBA-ankerk. 5.2.3 | Okt. 1993 | |
| | LBA-ankerk. 5.2.4 | Okt. 1993 | |
| | 5.3.1 | Okt. 1993 | |
| | 5.3.2.1 | Feb. 1996 | TM396-3/MB396-7 |
| | 5.3.2.2 | Feb. 1996 | TM396-3/MB396-7 |

0.2 Verzeichnis der Seiten / List of effective pages

| Ab-schnitt | Seite | Ausgabe-datum | Bezug |
|------------|-------|---------------|-------|
| 6 | 6.1.1 | Okt. 1993 | |
| | 6.1.2 | Okt. 1993 | |
| | 6.2.1 | Okt. 1993 | |
| | 6.2.2 | Okt. 1993 | |
| | 6.2.3 | Okt. 1993 | |
| | 6.2.4 | Okt. 1993 | |
| | 6.2.5 | Okt. 1993 | |
| | 6.2.6 | Okt. 1993 | |
| | 6.2.7 | Okt. 1993 | |
| | 6.2.8 | Okt. 1993 | |

0.2 Verzeichnis der Seiten / List of effective pages

| Abschnitt Affected section | Seite Affected pages | Ausgabe-Datum Date of issue | Bezug Reference | |
|-------------------------------|-------------------------|--------------------------------|--------------------|-----------|
| 7 | 7.1.1 | Oktober 1993 | MB 396-14 | |
| | 7.1.2 | Oktober 1993 | | |
| | 7.2.1 | Februar 2004 | | |
| | 7.2.2 | Oktober 1993 | | |
| | 7.2.3 | Oktober 1993 | | |
| | 7.2.4 | Oktober 1993 | | |
| | 7.2.5 | Oktober 1993 | | |
| | 7.2.6 | Oktober 1993 | | |
| | 7.2.7 | Februar 2004 | | MB 396-14 |
| | 7.3.1 | Februar 2004 | | MB 396-14 |
| | 7.3.2 | Februar 1996 | TM 396-3/MB 396-7 | |
| | 7.4 | Oktober 1993 | TM 396-3/MB 396-7 | |
| | 7.5 | Oktober 1993 | | |
| | 7.6 | Februar 1996 | | |
| | 7.7 | Oktober 1993 | | |
| | 7.8 | Oktober 1993 | | |
| | 7.9.1 | Oktober 1993 | | |
| | 7.9.2 | Oktober 1993 | | |
| 7.9.3 | Oktober 1993 | | | |
| 7.10 | Oktober 1993 | | | |
| 7.11 | Oktober 1993 | | | |
| 7.12.1 | Oktober 1993 | | | |
| 7.12.2 | Oktober 1993 | | | |
| 7.13.1 | Oktober 1993 | | | |
| 7.13.2 | Oktober 1993 | | | |

0.2 Verzeichnis der Seiten / List of effective pages

| Abschnitt | Seite | Ausgabe-Datum | Bezug |
|-----------|---|---|--------|
| 8 | 8.1.1 8.1.2 8.2 8.3 8.4 8.5.1 8.5.2 | Oktober 1993 Oktober 1993 Oktober 1993 Juni 2005 Oktober 1993 Oktober 1993 Oktober 1993 | Rev. 9 |

0.2 Verzeichnis der Seiten / List of effective pages

| Ab- schnitt | Seite | Ausgabe- datum | Bezug |
|----------------|-----------------------|------------------------|-------|
| 9 | 9.1.1 9.1.2 9.2 | Okt. 1993 Okt. 1993 | |

0.3 Table of contents

| | Section |
|--|---------|
| General (a non-approved section) | 1 |
| Limitations (an approved section) | 2 |
| Emergency procedures (an approved section) | 3 |
| Normal procedures (an approved section) | 4 |
| Performance (a partly approved section) | 5 |
| Weight and balance (a non-approved section) | 6 |
| Sailplane and systems description (a non-approved section) | 7 |
| Sailplane handling, care and maintenance (a non-approved section) | 8 |
| Supplements | 9 |

Section 1

- 1. General**
- 1.1 Introduction**
- 1.2 Certification basis**
- 1.3 Warnings, cautions and notes**
- 1.4 Descriptive data**
- 1.5 Three-side view**

1.1 Introduction

The Flight Manual for this sailplane has been prepared to provide pilots and instructors with information for the safe and efficient operation of the "Duo Discus".

This manual includes the material required to be furnished to the pilot by "JAR", Part 22.

It also contains supplemental data supplied by the manufacturer of the sailplane.

1.2 Certification Basis

This sailplane, model designation

" D u o D i s c u s ",

has been approved by the Luftfahrt Bundesamt (LBA) in compliance with "JAR", Part 22, effective on June 27, 1989 (Change 4 of the English Original Issue), including additional Amendments 22/90/1, 22/91/1 and 22/92/1.

The LBA Type Certificate is No. 396 and was issued on : March 21st, 1994

Category of Airworthiness : UTILITY

1.3 Warnings, cautions and notes

The following definitions apply to warnings, cautions and notes used in this flight manual:

"WARNING" means that the non-observation of the corresponding procedure leads to an immediate or important degradation of the flight safety

"CAUTION" means that the non-observation of the corresponding procedure leads to a minor or to a more or less long term degradation of the flight safety

"NOTE" draws the attention on any special item not directly related to safety, but which is important or unusual.

1.4 Descriptive data

The "Duo Discus" is a two-seat sailplane for advanced training and cross-country flying, constructed from glass and carbon fiber reinforced plastic (GFRP/CFRP), featuring a T-tail (with fixed horiz. stabilizer and elevator).

Wing

The wing is four-stage trapezoid in planform, consists of two main panels with tip extension (having a swept-back leading edge) and has double-panel "Schempp-Hirth" type airbrakes on the upper surface. Ailerons are internally driven.

The integral water ballast tanks have a total capacity of approx. 198 Liter (52.3 US Gal., 43.5 IMP Gal.).

The wing shells are a glass fiber/foam-sandwich construction with spar flanges of carbon fiber rovings and shear webs made as a GFRP/foam-sandwich.

Fuselage

The cockpit is comfortable and features two seats in tandem. The one-piece canopy hinges sideways and opens to the right. The fuselage is constructed as a pure glass fiber non-sandwich shell and is thus highly energy absorbing. While its aft section is stiffened by GFRP/foam-sandwich bulkheads and webs, the cockpit region is reinforced by a double skin on the sides, with integrated canopy coaming frame and seat pan mounting flanges. The main wheel is retractable and features a hydraulic disc brake; nose wheel and tail wheel (or skid) are fixed.

Horizontal tailplane

The horiz. tailplane consists of a fixed stabilizer with elevator. The stabilizer is a GFRP/foam-sandwich construction with CFRP-reinforcements, the elevator halves are a pure CFRP/GFRP shell.

The spring trim is gradually adjustable by a lever resting against a threaded rod.

Vertical tail

Fin and rudder are constructed as a GFRP/foam-sandwich. On request a water ballast trim tank with a capacity of 11 Liter (2.9 US Gal., 2.4 IMP Gal.) is provided in the fin.

Controls

All controls are automatically hooked up when the sailplane is rigged.

SCHEMPP-HIRTH FLUGZEUGBAU GMBH, KIRCHHEIM/TECK

Duo Discus

FLIGHT MANUAL

- Intentionally left blank -

October 1993
Revision -

1.4.2

SCHEMPP-HIRTH FLUGZEUGBAU GMBH, KIRCHHEIM/TECK

Duo Discus

FLIGHT MANUAL

TECHNICAL DATA

| | | | |
|------------------|---------------------|----------------------|--|
| <u>Wing_</u> | Span | 20.00 m | 65.62 ft |
| | Area | 16.40 m ² | 176.53 ft ² |
| | Aspect ratio | | 24.4 |
| | MAC | 0.875 m | 2.87 ft |
| <u>Fuselage_</u> | Length | 8.62 m | 28.28 ft |
| | Width | 0.71 m | 2.33 ft |
| | Height | 1.00 m | 3.28 ft |
| <u>Mass_</u> | Empty mass approx. | 420 kg | 926 lb |
| | Maximum all-up mass | 700 kg | 1543 lb |
| | Wing loading | 29.9 - 6.1 | 42.7 - 8.7 kg/m ² lb/ft ² |

October 1993
Revision -

1.4.3

Duo Discus

1.5 Three-side view

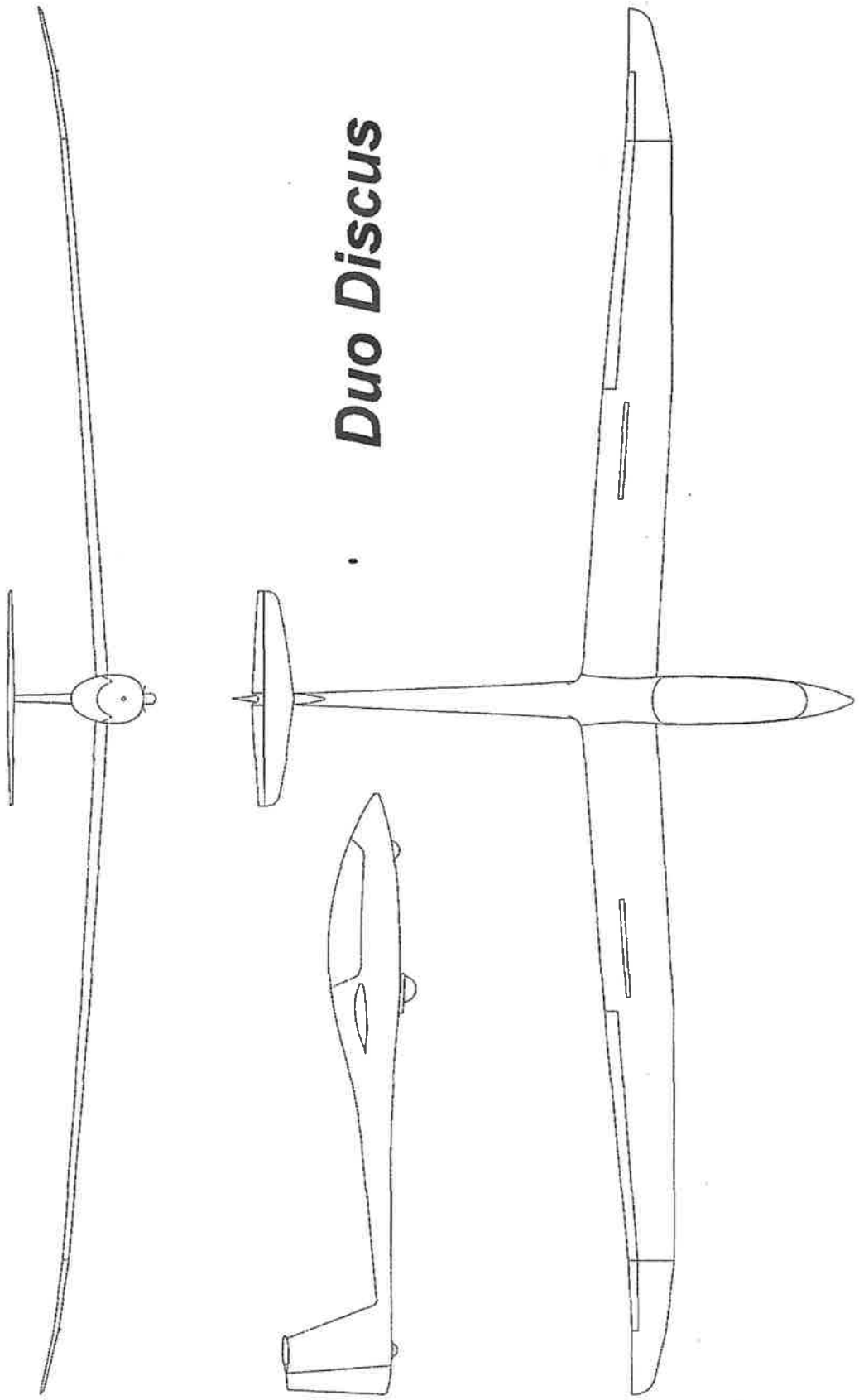

Section 2

- 2. Limitations
 - 2.1 Introduction
 - 2.2 Airspeed
 - 2.3 Airspeed indicator markings
 - 2.4 (reserved)
 - 2.5 (reserved)
 - 2.6 Weights (masses)
 - 2.7 Center of gravity
 - 2.8 Approved maneuvers
 - 2.9 Maneuvering load factors
 - 2.10 Flight crew
 - 2.11 Kinds of operation
 - 2.12 Minimum equipment
 - 2.13 Aerotow and winch launch
 - 2.14 Other limitations
 - 2.15 Limitation placards

2.1 Introduction

Section 2 includes operating limitations, instrument markings and basic placards necessary for safely operating the sailplane, its standard systems and standard equipment.

The limitations included in this section and in section 9 have been approved by the Luftfahrt Bundesamt (LBA), Braunschweig.

2.2 Airspeed

Airspeed limitations and their operational significance are shown below:

| SPEED | | (IAS) | REMARKS |
|----------|--------------------------------------|-------------------------------|--|
| V_{NE} | Never exceed speed in calm air | 250 km/h 135 kt 155 mph | Do not exceed this speed in any operation and do not use more than 1/3 of control deflection. |
| V_{RA} | Rough air speed | 180 km/h 97 kt 112 mph | Do not exceed this speed except in smooth air, and then only with caution. Rough air is met in lee-wave rotors, thunderclouds etc. |
| V_A | Maneuvering speed | 180 km/h 97 kt 112 mph | Do not make full or abrupt control movements above this speed as the aircraft structure might get overstressed. |
| V_T | Maximum speed on aerotow | 180 km/h 97 kt 112 mph | Do not exceed this speed during an aerotow. |
| V_W | Maximum winch launch speed | 150 km/h 81 kt 93 mph | Do not exceed this speed during a winch launch. |
| V_{LO} | Maximum landing gear operating speed | 180 km/h 97 kt 112 mph | Do not extend or retract landing gear above this speed. |
| | | | |

2.3 Airspeed indicator markings

Airspeed indicator markings and their colour code significance are shown below:

| MARKING | VALUE OR RANGE (IAS) | SIGNIFICANCE |
|--------------------------|--|---|
| Green arc | 90 - 180 km/h 49 - 97 kt 56 - 112 mph | <u>Normal operating range</u> (Lower limit is the speed $1.1 V_{S1}$ at maximum mass and c/g in most forward position. Upper limit is the max. permissible speed in rough air). |
| Yellow arc | 180 - 250 km/h 97 - 135 kt 112 - 155 mph | Maneuvers must be conducted with caution and operating in rough air is not permitted. |
| Red line at | 250 km/h 135 kt 155 mph | Maximum speed for all operations. |
| Yellow triangle at | 100 km/h 54 kt 62 mph | Approach speed at maximum mass without water ballast. |
| | | |

SCHEMPP-HIRTH FLUGZEUGBAU GMBH, KIRCHHEIM/TECK

Duo Discus

FLIGHT MANUAL

- Intentionally left blank -

October 1993
Revision -

LBA-app.
2.4

SCHEMP-P-HIRTH FLUGZEUGBAU GMBH, KIRCHHEIM/TECK

Duo Discus

FLIGHT MANUAL

- Intentionally left blank -

October 1993
Revision -

LBA-app.
2.5

2.6 Weights (masses)

| | |
|---|------------------|
| Maximum permitted take-off mass : | 700 kg (1543 lb) |
| Maximum permitted landing mass : | 700 kg (1543 lb) |
| Maximum permitted take-off and landing mass w i t h o u t water ballast : | 660 kg (1455 lb) |
| Maximum permitted mass of all non-lifting parts : | 440 kg (970 lb) |
| Maximum permitted mass in baggage compartment : | --- --- |

2.7 Center of gravityCenter of gravity in flight

Sailplane attitude: Tail jacked up such that a wedge-shaped block, 100 : 4.5, placed on the rear top fuselage, is horizontal along its upper edge.

Datum : Wing leading edge at root rib

Maximum forward
c/g position : 45 mm (1.77 in.) aft of datum
plane

Maximum rearward
c/g position : 250 mm (9.84 in.) aft of datum
plane

It is extremely important that the maximum rearward c/g position is not exceeded.

This requirement is met when the minimum front seat load is observed.

The minimum front seat load is given in the loading table and is shown by a placard in the cockpit.

A lower front seat load must be compensated by ballast - see section 6.2 "Weight and Balance Record / Permitted Payload Range".

2.8 Approved maneuvers

The sailplane model "Duo Discus" is certified in category

U T I L I T Y

for normal sailplanes.

WARNING:

Aerobatic maneuvers and cloud flying
n o t approved!

2.9 Maneuvering load factors

The following maneuvering load factors must not be exceeded when the sailplane is pulled up:

- a) With airbrakes locked and at $V_A =$
180 km/h, 97 kt, 112 mph

$$n = + 5.3$$

$$n = - 2.65$$

With airbrakes locked and at $V_{NE} =$
250 km/h, 135 kt, 155 mph

$$n = + 4.0$$

$$n = - 1.5$$

- b) With airbrakes extended, the maximum maneuvering load factor is

$$n = + 3.5 \text{ at } V_{NE}$$

2.10 Flight crew

When flown solo, the "Duo Discus" is controlled from the front seat.

Observe the minimum load on the front seat - if necessary, ballast must be installed to bring the load up to a permissible figure. See also section 6.2:

"Weight and Balance Record / Permitted Payload Range".

2.11 Kinds of operation

With the prescribed minimum equipment installed
(see page 2.12), the "Duo Discus" is approved for

VFR-flying in daytime.

2.12 Minimum equipment

Instruments and other basic equipment must be of an approved type and should be selected from the list in the Maintenance Manual.

Normal operations

- 2 Airspeed indicator (range up to 300 km/h, 162 kt, 186 mph) with colour markings according to page 2.3
- 2 Altimeter
- 1 Outside air temperature indicator (OAT) with sensor (when flying with water ballast, red line at +2° C)
- 2 Four-piece safety harnesses (symmetrical)
- 2 Automatic or manual parachutes
or
- 2 Back cushions (thickness approx. 10 cm/3.9 in. when compressed)

Caution:

The sensor for the OAT must be installed in the ventilation air intake.

For structural reasons the mass of each instrument panel with instruments in place must not exceed 10 kg (22 lb).

2.13 Aerotow and winch launchAerotow

| | |
|---------------------------------|-----------------------------------|
| Maximum towing speed : | 180 km/h (97 kt, 112 mph) |
| Weak link in tow rope : | 700 - 910 daN (1543 - 2006 lb) |
| Minimum length of tow rope : | 30 m (98 ft) |
| Tow rope material : | Hemp or Nylon |

Winch launch

| | |
|-------------------------------|-----------------------------------|
| Max. launching speed : | 150 km/h (81 kt, 93 mph) |
| Weak link in winch cable : | 700 - 910 daN (1543 - 2006 lb) |

2.14 Other limitations

N o n e

2.15 Limitation placards

| | | | |
|--|-----|-----|-----|
| MAXIMUM PERMITTED ALL-UP MASS: 700 kg (1543 lb) | | | |
| MAXIMUM PERMITTED SPEEDS (IAS): km/h kt mph | | | |
| Never exceed speed | 250 | 135 | 155 |
| Rough air speed | 180 | 97 | 112 |
| Maneuvering speed | 180 | 97 | 112 |
| Aerotowing speed | 180 | 97 | 112 |
| Winch launching speed | 150 | 81 | 93 |
| Landing gear operating speed | 180 | 97 | 112 |

fin tank n o t installed

| LOAD ON THE SEATS (crew incl. parachutes) | | | | |
|---|-------------------|--------------------|-------------------|--------------------|
| SEAT LOAD | TWO PERSONS | | ONE PERSON | |
| | min. | max. | min. | max. |
| front seat load | 70* kg 154* lb | 110* kg 243* lb | 70* kg 154* lb | 110* kg 243* lb |
| rear seat load | at choice | 110* kg 243* lb | _____ | _____ |
| Loads of less than the above minimum must be raised by using trim ballast - see instructions given in section 6.2 of the Flight Manual. | | | | |

fin tank i n s t a l l e d

| LOAD ON THE SEATS (crew incl. parachutes) | | | | |
|--|--|--------------------|--|--------------------|
| SEAT LOAD | TWO PERSONS | | ONE PERSON | |
| | min. | max. | min. | max. |
| front seat load | 100* kg 220* lb (70*)kg (154*)lb | 110* kg 243* lb | 100* kg 220* lb (70*)kg (154*)lb | 110* kg 243* lb |
| rear seat load | at choice | 110* kg 243* lb | _____ | _____ |
| Loads of less than the above minimum must be raised by using trim ballast - see instructions given in section 6.2 of the Flight Manual. The value shown in parenthesis may be used after having thoroughly checked the ballast quantity in the fin tank and the appropriate loading chart. | | | | |

* As the actual minimum or maximum load on the seats of this "Duo Discus" (to which this manual refers) may differ from these typical weights, the placards in the cockpit must always show the actual weights, which are also to be entered in the log chart - see page 6.2.3.

| | |
|---|------------------|
| WEAK LINK FOR TOWING | |
| for Aerotow and Winch launch: max. 910 daN (2006 lb) | |
| TIRE PRESSURE | |
| Nose wheel : | 3.0 bar (43 psi) |
| Main wheel : | 4.0 bar (57 psi) |
| Tail wheel : | |
| (if installed) | 3.0 bar (43 psi) |

Notes

Further placards are shown in the Maintenance Manual

January 2000
Revision 5

TN 396 - 5
MB 396 - 10

LBA-app.
2.15

Section 3

- 3. **Emergency procedures**

- 3.1 **Introduction**

- 3.2 **Canopy jettisoning**

- 3.3 **Bailing out**

- 3.4 **Stall recovery**

- 3.5 **Spin recovery**

- 3.6 **Spiral dive recovery**

- 3.7 **(reserved)**

- 3.8 **(reserved)**

- 3.9 **Other emergencies**

3. Emergency procedures

3.1 Introduction

Section 3 provides check lists and amplifies procedures for coping with emergencies that may occur.

Emergency situations can be minimized by proper pre-flight inspections and maintenance.

3.2 Jettisoning the canopy

The canopy is to be jettisoned as follows:

Swing back one of the red locking levers -
provided on the port side of the canopy frame -
and swing canopy sideways fully open.

The canopy will then be torn out from its
hinges by the airstream and gets carried
away.

3.3 Bailing out

With the canopy gone, the person(s) aboard may bail out.

As the canopy coaming frame on the fuselage is made from laminated rovings - so that it is strong and without sharp edges - the person on the front seat can grasp it and use it as a support when bailing out.

Additionally the crew member on the rear seat can raise himself by grabbing the cut-outs provided on either side of the instrument panel.

3.4 Stall recovery

On stalling whilst flying straight ahead or in a banked turn, normal flying attitude is regained by firmly easing the control stick forward and, if necessary, applying opposite rudder and aileron.

3.5 Spin recovery

A safe recovery from a spin is effected by the following method:

- a) Hold ailerons neutral.
- b) Apply opposite rudder (i.e. against the direction of rotation of the spin).
- c) Ease control stick forward until rotation ceases and the airflow is restored.
- d) Centralize rudder and pull gently out of dive.

With the center of gravity in rearward positions, a steady spinning motion is possible.

After having applied the standard recovery method, the sailplane will stop rotating after about 1/4 to 1/2 turn.

The loss of height - from the point at which recovery is initiated to the point at which horizontal flight is first regained - can be up to about 100 m (328 ft), and the recovery speeds are between 130 and 170 km/h (70-92 kt, 81-106 mph).

With the center of gravity in the foremost position, a steady spinning motion is not possible. The sailplane stops rotating after a half or a full turn and usually enters a spiral dive.

Recovery is by normal use of opposite controls.

Note: Spinning may be safely avoided by following the actions given in section 3.4 "Stall recovery".

3.6 Spiral dive recovery

Depending on the use of the controls, a spin may turn into a spiral dive, if the center of gravity is in a forward position. This is indicated by a rapid increase in speed and acceleration.

Recovery from a spiral dive is achieved by easing the control stick forward and applying opposite rudder and aileron.

WARNING:

When pulling out of the dive, the permissible control surface deflections at V_A / V_{NE} are to be observed!
See also page 2.2.

SCHEMPP-HIRTH FLUGZEUGBAU GMBH, KIRCHHEIM/TECK

Duo Discus

FLIGHT MANUAL

3.7 - INTENTIONALLY LEFT BLANK -

October 1993
Revision -

LBA-app.
3.7

SCHEMP-HIRTH FLUGZEUGBAU GMBH, KIRCHHEIM/TECK

Duo Discus

FLIGHT MANUAL

3.8 - INTENTIONALLY LEFT BLANK -

**October 1993
Revision -**

**LBA-app.
3.8**

3.9 Other emergencies

Flying with uneven water ballast

If, on dumping water ballast, the wing tanks are emptying unevenly or only on one side - which is recognized at lower speeds by having to apply opposite aileron for normal flying attitude - entering a stall must be avoided.

When landing in this condition, the touch down speed must be increased by about 10 km/h (5 kt, 6 mph) and the pilot must be prepared for the sailplane to veer off course as the heavier wing tends to drop somewhat sooner than normal (apply opposite aileron).

Emergency landing with retracted undercarriage

An emergency landing with the main wheel retracted is on principle not recommended, because the potential energy absorption of the landing gear is many times higher as compared to the fuselage shell.

Should the wheel fail to extend, the sailplane should be landed at a flat angle and without pancaking.

Ground loop

If there is the danger of the sailplane overshooting the boundary of the landing field in mind, a decision whether or not to initiate a controlled ground loop should be made at least about 40 m (131 ft) away from the boundary:

- If possible, always turn into the wind and
- as the wing tip is forced down, push the control stick forward simultaneously.

Emergency water landing

From experience gained on the occasion of a composite sailplane landing on water with its undercarriage retracted, the crew must take into consideration that, in the case of the "Duo Discus", the entire cockpit might get forced under water.

Therefore an emergency landing on water should only be chosen as a last resort and the main wheel should always be extended.

Duo Discus

Section 4

- 4. Normal operating procedures
 - 4.1 Introduction
 - 4.2 Rigging and de-rigging
 - 4.3 Daily inspection
 - 4.4 Pre-flight inspection
 - 4.5 Normal procedures and recommended speeds
 - 4.5.1 Methods of launching
 - 4.5.2 (reserved)
 - 4.5.3 Flight
 - 4.5.4 Approach
 - 4.5.5 Landing
 - 4.5.6 Flight with water ballast
 - 4.5.7 High altitude flight
 - 4.5.8 Flight in rain
 - 4.5.9 Aerobatics

4. Normal operating procedures

4.1 Introduction

Normal procedures associated with optional equipment are found in section 9.

This section provides check lists and amplifies procedures for conducting the daily and pre-flight inspection.

Furthermore this section includes normal operating procedures and recommended speeds.

4.2 Rigging and de-riggingRigging

The "Duo Discus" can be rigged by two people if a wing stand or trestle is used under one wing tip.

Prior to rigging, all pins and their corresponding bearings on fuselage, wing panels and tailplane should be cleaned and greased.

Inboard wing panels

Unlock airbrake lever and set water ballast control knob at "closed".

Insert the port wing panel first. It is important that the helper on the wing tip should concentrate on lifting the trailing edge of the wing panel more than the leading edge, so that the rear wing attachment pin does not force the inner race of the swivel bearing on the fuselage down and out of alignment.

Check that the spar stub tip is located correctly in the cut-out on the far side of the fuselage (if necessary, tilt the fuselage or move the wing gently up and down to help it home).

Check that the angular levers on the wing root rib are properly inserted into their corresponding funnels on the fuselage.

Push in main wing pin approx. 3 cm (1.2 in.) so that the wing panel is prevented from sliding out by the CFRP-cover of the front wing suspension tube. The panel tip can now be placed on a wing stand.

Next insert the starboard panel - the procedure is the same as for the port wing panel. As soon as the pin on the starboard spar stub has engaged in its corresponding bearing on the opposing wing panel (recognized by a sudden extension of the unlocked airbrakes), the starboard panel can be pushed fully home under some pressure.

If it is difficult/impossible to push the panel fully home, remove main wing pin and draw the panels together with the aid of the rigging lever (use flat side only).

Finally push main wing pin fully home and secure its handle.

Wing tip extensions (outbd. panels)

Insert spar of wing tip extension – with locking pin pushed down and aileron deflected upwards – into the spar tunnel of the inboard wing panel. When fully home, the spring-loaded pin must have engaged (snapped up) in the corresponding opening on the inboard wing panel. Make sure that the coupling lap on the lower side of the inner aileron has correctly slid under the adjacent outer aileron.

If the locking pin has not snapped up, it has to be pushed up from the lower side with the aid of the tailplane rigging pin.

Horizontal tailplane

Take the round-headed rigging tool (to be stored in the side-pocket) and screw into the front tailplane locating pin on the leading edge of the fin. Thereafter slide the tailplane aft onto the two elevator actuating pins, pull rigging tool and its pin forwards, seat stabilizer nose and push locating pin home into the front tailplane attachment fitting.

Remove rigging tool – locating pin must not protrude in front of the leading edge of the fin.

Check whether the elevator actuating pins are really located by moving the elevator.

After rigging

Check – with the aid of a helper – the controls for full and free movement in the correct sense.

Use tape to seal off the wing / fuselage joint and the joint between main wing panels and their tip extension.

Caution: Do not seal off the gap between the aileron on the tip extension and the aileron on the main wing panel.

Seal off the opening for the front tailplane attachment pin and also the joint between fin and horizontal stabilizer (only necessary if there is no rubber sealing on the upper end of the fin).

Sealing with tape is beneficial in terms of performance and it also serves to reduce the noise level.

De-rigging

Remove sealing tape from fuselage-to-wing fillets and from the fin.

Horizontal tailplane

Using the threaded rigging pin, pull out front tailplane attachment pin, lift stabilizer leading edge slightly and pull tailplane forwards and off.

Wing tip extensions (outbd. panels)

Push locking pin down (using the tailplane rigging pin) and carefully pull out tip extension.

Main wing panels

Unlock airbrakes, set water dump valve control knob to the "closed" position and unlock handle of main wing pin.

With a helper on the tip of each wing panel, pull out main wing pin up to the last 20 to 30 mm (0.8 - 1.2 in.) and withdraw the starboard panel by gently rocking it backwards and forwards if necessary.

Thereafter remove main wing pin and withdraw the port wing panel.

4.3 Daily inspection

The importance of inspecting the sailplane after rigging and before commencing the day's flying cannot be over-emphasized, as accidents often occur when these daily inspections are neglected or carried out carelessly.

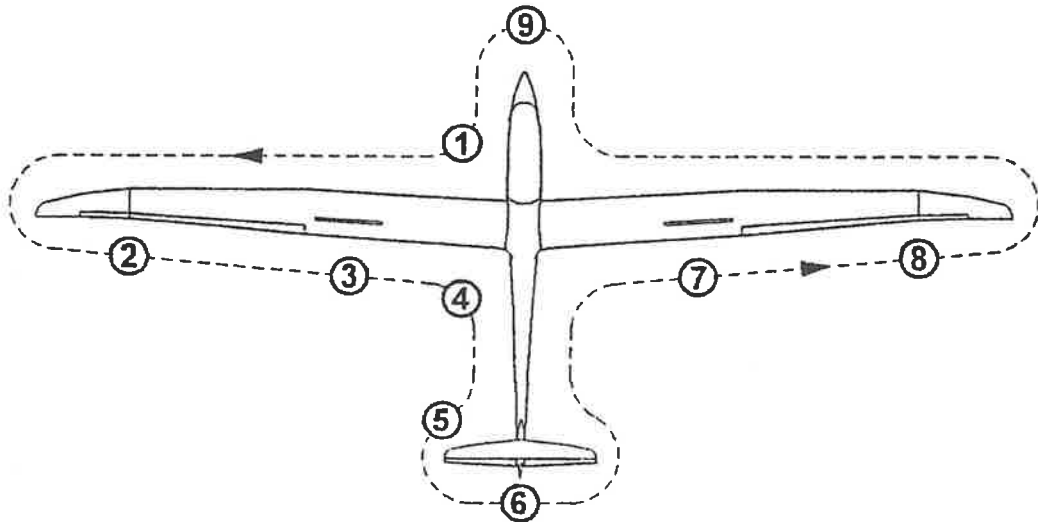

When walking around the "Duo Discus", check all surfaces for paint cracks, dents and unevenness. In case of doubt, ask an expert for his advice.

- ① a) Open canopy
- b) Check that the main wing pin is properly secured
- c) Make a visual check of all accessible control circuits in the cockpit
- d) Check for full and free movements of the control elements

- e) Check for the presence of foreign objects
- f) (reserved)
- g) (reserved)
- h) Check tire pressure:
 - Nose wheel: 3.0 bar (43 psi)
 - Main wheel: 4.0 bar (57 psi)
- i) Check tow release mechanism(s) for proper condition and function

2

- a) Check upper and lower wing surface for damage
- b) Clean and grease water ballast dump valves (if necessary)
- c) Check wing tip extensions for proper connection (locking pin must be flush with upper wing surface)
- d) Check that the ailerons are in good condition and operate freely. Check for any unusual play by gently shaking the trailing edge. Check hinges for damage

3

- Check airbrakes for proper condition, fit and locking

- ④
- a) Check fuselage for damage, especially on its lower side
 - b) Check that the Static pressure ports for the ASI on the tail boom (1.02 m/3.35 ft forward of the base of the fin) and below the fuselage-to-wing fillet are clear
- ⑤
- a) Check condition of tail skid or wheel.
If the latter is installed, check tire pressure:

3.0 bar (43 psi)
 - b) Should a total energy compensation probe be used, mount it and check the line (when blowing gently into the probe, variometer(s) connected should read "climb")
 - c) (reserved)
 - d) Check that the Pitot pressure head is clear.
Gently blowing into the head should produce a reading on the airspeed indicator

Should a water ballast fin tank be installed (option):

- e) Check that the fin tank spill holes are clear
- f) Check water ballast level in fin tank (in case of doubt, discharge ballast)
- g) Check that the dump hole for the fin tank in the tail wheel fairing is clear

- ⑥
 - a) Check horizontal tailplane for proper attachment and locking
 - b) Check elevator and rudder for free movement
 - c) Check trailing edge of elevator and rudder for damage
 - d) Check elevator and rudder for any unusual play by gently shaking the trailing edge

- ⑦ See (3)
- ⑧ See (2)
- ⑨ Reserved

After heavy landings or after the "Duo Discus" has been subjected to excessive loads, the resonant wing vibration frequency should be checked (its value to be extracted from the last inspection report for this serial number).

Check the entire sailplane thoroughly for surface cracks and other damage. For this purpose it should be de-rigged.

If damage is discovered (e.g. surface cracks in the fuselage tail boom or tailplane, or if delamination is found at the wing roots or at the bearings in the root ribs), then the sailplane must be grounded until the damage has been repaired by a qualified person.

4.4 Pre-flight inspection

CHECK LIST BEFORE TAKE-OFF

- Water ballast in fin tank ? (if installed)
- Loading charts checked ?
- Parachute securely fastened ?
- Safety harness secured and tight ?
- Seat back, head rest and pedals in comfortable position ?
- All controls and instruments accessible ?
- Airbrakes checked and locked ?
- All control surfaces checked with assistant for full and free movement in correct sense ?
- Elevator trim correctly set ?
- Canopy closed and locked ?

4.5 Normal operating procedures and recommended speeds4.5.1 Methods of launchingAerotow

ONLY PERMISSIBLE WITH NOSE TOW RELEASE IN PLACE

Maximum permitted towing speed:

$$V_T = 180 \text{ km/h (97 kt, 112 mph)}$$

For aerotow only the nose tow release must be used - hemp and nylon ropes of between 30 and 40 m length (98-131 ft) were tested.

Prior to take-off set elevator trim as follows:

- Rearward c/g positions : Lever forward to first third of its travel
- Other c/g positions : Lever to the middle of its travel

As the tow rope tightens, apply the wheel brake gently (by actuating the stick-mounted lever) to prevent the "Duo Discus" from overrunning the rope.

In crosswind conditions the aileron control should be held towards the downwind wing, i.e. in winds from the left the stick should be displaced to the right. This is to counteract the lift increase on the right wing generated by the tug's prop wake, which the crosswind forces to drift to the right.

For intermediate to forward c/g positions the elevator should be neutral for the ground run; in the case of rearward c/g positions it is recommended that down elevator is applied until the tail lifts.

After lift-off the elevator trim can be set for a minimum in control stick loads.

When flown solo, the normal towing speed is in the region of 100 to 120 km/h (54-65 kt, 62-75 mph) and 130 to 140 km/h (70-76 kt, 81-87 mph) for two occupants flying with water ballast.

Only small control surface deflections are necessary to keep station behind the tug.

In gusty conditions or when flying into the propeller slip stream of a powerful tug correspondingly greater control stick movements are required.

NOTE:

The minimum towing speeds are lower for aero tow with a powered sailplane:

- 95 km/h (51 kt, 59 mph) (when flown solo)
- 105 km/h (56 kt, 65 mph) (for two occupants with water ballast)

The undercarriage may be retracted during the tow; this is not, however, recommended at low altitude, as changing hands on the stick could easily cause the "Duo Discus" to lose station behind the tug.

When releasing the tow rope, pull the yellow T-shaped handle fully several times and turn only when definitely clear of the rope.

Winch launch

ONLY PERMISSIBLE WITH C/G TOW RELEASE IN PLACE

Maximum permitted launching speed:

$$V_W = 150 \text{ km/h (81 kt, 93 mph)}$$

For winch launching only the c/g tow release must be used.

Prior to take-off set elevator trim as follows:

- Rearward c/g positions: : Lever forward to first third of its travel
- Intermediate c/g positions: : Lever in the middle of its travel
- Forward c/g positions : Lever backward to last third of its travel

As the cable tightens, apply the wheel brake gently (by actuating the stick-mounted lever) to prevent the "Duo Discus" from overrunning the winch cable.

Ground run and lift-off are normal - there is no tendency to veer-off or to climb excessively steeply on leaving the ground.

Depending on the load on the seats, the "Duo Discus" is lifted off with the control stick slightly pushed forward in the case of aft c/g positions and slightly pulled back with the c/g in a forward position.

After climbing to a safe height, the transition into a typical steep winch launch attitude is effected by pulling the control stick slightly further back.

At normal all-up masses, i.e. without water ballast, the launch speed should not be less than 90 km/h (49 kt, 56 mph), and with water ballast and both seats occupied not less than 100 to 110 km/h (54-59 kt, 62-68 mph).

Normal launch speed is about 100 km/h (54 kt, 62 mph), with water ballast about 110 to 120 km/h (59-65 kt, 68-75 mph).

At the top of the launch the cable will normally back-release automatically; the cable release handle should, nevertheless, be pulled firmly several times to ensure that the cable has actually gone.

CAUTION:

Winch launching at the maximum permitted all-up mass of 700 kg (1543 lb) should only be done if there is an appropriately powerful winch and a cable in perfect condition available.

Furthermore there is not much point in launching by winch for a soaring flight, if the release height gained is less than 300 m (984 ft).

In case of doubt, reduce all-up mass (by dumping all water ballast).

Winch launching with water ballast is not recommended if the head wind is less than 20 km/h (11 kt).

WARNING: It is explicitly advised against winch launching with a tail wind!

CAUTION:

Prior to launching by winch, it must be ensured that the crew is properly seated and able to reach all control elements.

Particularly when using seat cushions it must be made sure that during the initial acceleration and while in the steep climbing attitude the occupants do not slide backwards and up.

SCHEMPP-HIRTH FLUGZEUGBAU GMBH, KIRCHHEIM/TECK

Duo Discus

FLIGHT MANUAL

4.5.2 - Intentionally left blank -

**October 1993
Revision -**

**LBA-app.
4.5.2**

4.5.3 Flight

The "Duo Discus" has pleasant flight characteristics and can be flown effortlessly at all speeds, loading conditions (with or without water ballast), configurations and c/g positions.

With a mid-point c/g position the maximum speed range covered by the elevator trim is from about 70 km/h (38 kt, 43 mph) to about 200 km/h (108 kt, 124 mph).

Flying characteristics are pleasant and the controls are well harmonized. Turn reversal from + 45° to - 45° is effected without any noticeable skidding. Ailerons and rudder may be used to the limits of their travel.

| | | |
|---------------|----------------------------|-----------------------------|
| All-up mass | 513 kg 1131 lb | 700 kg 1543 lb |
| Speed | 99 km/h 53 kt 62 mph | 113 km/h 61 kt 70 mph |
| Reversal time | 4.6 sec | 4.6 sec |

Note:

Flights in conditions conducive to lightning strikes must be avoided.

High speed flying

At high speeds up to $V_{NE} = 250$ km/h (135 kt, 155 mph) the "Duo Discus" is easily controllable.

Full deflections of control surfaces may only be applied up to $V_A = 180$ km/h (97 kt, 112 mph).

At $V_{NE} = 250$ km/h (135 kt, 155 mph) only one third (1/3) of the full deflection range is permissible. Avoid especially sudden elevator control movements.

In strong turbulence, i.e. in wave rotors, thunderclouds, visible whirlwinds or when crossing mountain ridges, the speed in rough air $V_{RA} = 180$ km/h (97 kt, 112 mph) must not be exceeded.

With the c/g at an aft position, the control stick movement from the point of stall to maximum permissible speed is relatively small, though the change in speed will be noticed through a perceptible change in control stick loads.

The airbrakes may be extended up to $V_{NE} = 250$ km/h (135 kt, 155 mph). However, they should only be used at such high speeds in emergency or if the maximum permitted speeds are being exceeded inadvertently.

When extending the airbrakes suddenly, the deceleration forces are noticeable.

WARNING:

Consequently it is wise to check in advance that the harness is tight and that the control stick is not inadvertently thrown forwards when the airbrakes are extended. There should be no loose objects in the cockpit.

It should also be noted that in a dive with the airbrakes extended, the "Duo Discus" should be pulled out less abruptly than with retracted brakes (see section 2.9 "Maneuvering load factors").

A dive with the airbrakes fully extended is limited to an angle to the horizon of 30° at maximum permitted all-up mass at a speed of 250 km/h (135 kt, 155 mph).

Low speed flying and stall behaviour

In order to become familiar with the "Duo Discus" it is recommended to explore its low speed and stall characteristics at a safe height. This should be done whilst flying straight ahead and also whilst in a 45° banked turn.

Wings level stall

A stall warning usually occurs 5 to 7 km/h (3-4 kt, 3-4 mph) above stalling speed (CAS) and begins with vibration in the controls.

If the stick is pulled further back, this effect becomes more pronounced, the ailerons get spongy and the sailplane sometimes tends to slight pitching motions (speed increases again and will then drop to stalling speed).

On reaching a stalled condition - depending on the c/g position - a distinct drop of the ASI reading is observed, which then often oscillates because of turbulent air influencing the fin-mounted Pitot tube. With the c/g in rearward positions, the "Duo Discus" may slowly drop a wing, but usually it can be held level.

A normal flight attitude is regained by easing the control stick firmly forward and - if necessary - applying opposite rudder and aileron.

The loss of height from the beginning of the stall until regaining a normal level flight attitude is up to 30 m (98 ft).

In the case of forward c/g positions and stick fully pulled back, the sailplane just continues to fly in a mushed condition without the nose or a wing dropping.

Normal flying attitude is regained by easing the stick forward.

Turning flight stalls

When stalled during a coordinated 45° banked turn, the "Duo Discus" - with the control stick pulled fully back - just continues to fly in a stalled condition. There is no uncontrollable tendency to enter a spin. The transition into a normal flight attitude is conducted by an appropriate use of the controls.

The loss of height from the beginning of the stall until regaining a normal level flight attitude is approx. 20 to 30 m (66-98 ft).

Influence of water ballast

Apart from higher stall speeds - caused by the higher mass in flight - water ballast in the wing tanks has no aggravating influence on the stall characteristics.

With water ballast in the fin tank, stall characteristics are like those found for aft c/g positions.

4.5.4 Approach

Normal approach speed with airbrakes fully extended and wheel down is 90 km/h (49 kt, 56 mph) without water ballast and flown solo, or 105 km/h (57 kt, 65 mph) at maximum permitted all-up mass.

The yellow triangle on the ASI at the 100 km/h mark (54 kt, 62 mph) is the recommended approach speed for the maximum all-up mass without water ballast (660 kg/1455 lb).

In the above configurations the L/D is approximately 6.7 : 1.

The airbrakes open smoothly and are an effective landing aid.

Side slipping is also a fine aid for landing. It is possible in a straight line with the rudder deflected up to 85 % of its travel and results in a yaw angle of about 40° and a bank angle of about 25 to 30°. The control force reversal perceptible is low.

To return to level flight, normal opposite controls are required.

Caution:

With rudder fully deflected, side slips in a straight flight path are not possible - the sailplane will slowly turn in the direction of the displaced rudder.

WARNING:

Both the performance and the aerodynamic characteristics of the "Duo Discus" are affected adversely by heavy rain or ice on the wing. Be cautious when landing!

Increase the approach speed by at least 5 to 10 km/h (3-5 kt, 3-6 mph).

4.5.5 Landing

For off-field landings the undercarriage should always be extended, as the protection of the crew is much better, especially from vertical impacts on landing.

Main wheel and tail wheel should touch down simultaneously.

To avoid a long ground run, make sure that the sailplane touches down at minimum speed.

A touch-down at a speed of 90 km/h (49 kt, 56 mph) instead of 70 km/h (38 kt, 43 mph) means that the kinetic energy to be dissipated by braking is increased by a factor of 1.65 and therefore the ground run is lengthened considerably.

The hydraulic main wheel disc brake is actuated via the airbrake linkage with airbrakes almost fully extended.

As the effectiveness of the wheel brake is good, the landing run is considerably shortened (the elevator control should be kept fully back).

4.5.6 Flight with water ballast

If the maximum permitted all-up mass is to be reached, then water ballast is required.

Wing ballast tanks

The water tanks are integral compartments in the nose section of the main wing panels. These tanks are to be filled with clear water only, through round openings in the upper wing surface featuring a strainer.

Tank openings are closed with plugged-in filler caps having a 6 mm (0.24 in.) female thread for lifting and venting. Lifting these caps is done with the aid of the tailplane rigging pin.

WARNING:

As the threaded hole in the filler cap also serves for venting the tank, it must always be kept open!

Dumping the water from full tanks takes about five (5) minutes.

Each tank has a capacity of 99 Liter (26.15 US Gal., 21.78 IMP Gal.).

When filling the tanks it must be ensured that the maximum permitted all-up mass is not exceeded - see page 6.2.5.

The tank on either side must always be filled with the same amount of water to prevent lateral imbalance.

When taking off with partly full tanks, ensure that the wings are held level to allow the water to be equally distributed so that the wings are balanced.

Because of the additional mass in the wing panels, the wing tip runner should continue running for as long as possible during the launch.

Water ballast is dumped through an opening on the lower side of the main wing panels, 1.93 m (6.33 ft) away from the root rib.

The dump valves are hooked up automatically on rigging the sailplane (with water ballast control knob to be set at "CLOSED").

Thanks to baffles inside the ballast tanks there is no perceptible movement of the water ballast when flying with partly filled tanks.

When flying at maximum permitted all-up mass, the low speed and stall behaviour of the "Duo Discus" is slightly different from its flight characteristics without water ballast; The stall speeds are higher (see section 5.2.2) and for correcting the flight attitude larger control surface deflections are required. Furthermore more height is lost until a normal flight attitude is regained.

WARNING:

In the unlikely event of the tanks emptying unevenly or only one of them emptying (recognized by having to apply up to 50 % opposite aileron for a normal flight attitude), it is necessary to fly somewhat faster to take into account the higher mass and also to avoid stalling the sailplane.

During the landing run the heavier wing should be kept somewhat higher (if permitted by the terrain) so that it touches down only at the lowest possible speed. This reduces the danger of the "Duo Discus" to veer off course.

Duo Discus

Water ballast fin tank (optional)

For optimum performance in circling flight, the forward travel of the center of gravity, caused by water ballast in the wing nose and by the crew member on the aft seat, may be compensated by carrying water ballast in the fin tank.

For details concerning the quantities to be filled refer to page 6.2.8.

The water ballast tank is an integral compartment in the fin with a capacity of 11.0 kg/Liter (2.91 US Gal., 2.42 IMP Gal.). This tank is filled as follows - with the horizontal tailplane in place or removed:

Insert one end of a flexible plastic hose (outer diameter 8.0 mm/0.31 in.) into the tube (internal diameter 10.0 mm/0.39 in.) protruding from the rudder gap at the top of the fin on the left hand side. The other end of this hose is then connected to a suitable container which is to be filled with the required amount of clear water.

The fin tank has eleven (11) spill holes, all properly marked, on the right hand side of the fin, which indicate the water level - see accompanying sketch.

The venting of the tank is through the uppermost 11 kg/Liter hole (which always remains open - even with a full tank).

The ballast quantity to be filled, depends on the water load in the wing tanks and/or on the load on the aft seat - see loading tables on page 6.2.8.

Always tape closed one hole less than the load required, measured in kg/Liter.

If, for instance, a fin ballast load of 3.0 kg/Liter is required, only the lower two holes (1 and 2) are taped closed, any excessive water then escapes through the third spill hole, thus preventing any overloading.

Tank label on the right hand side of the fin

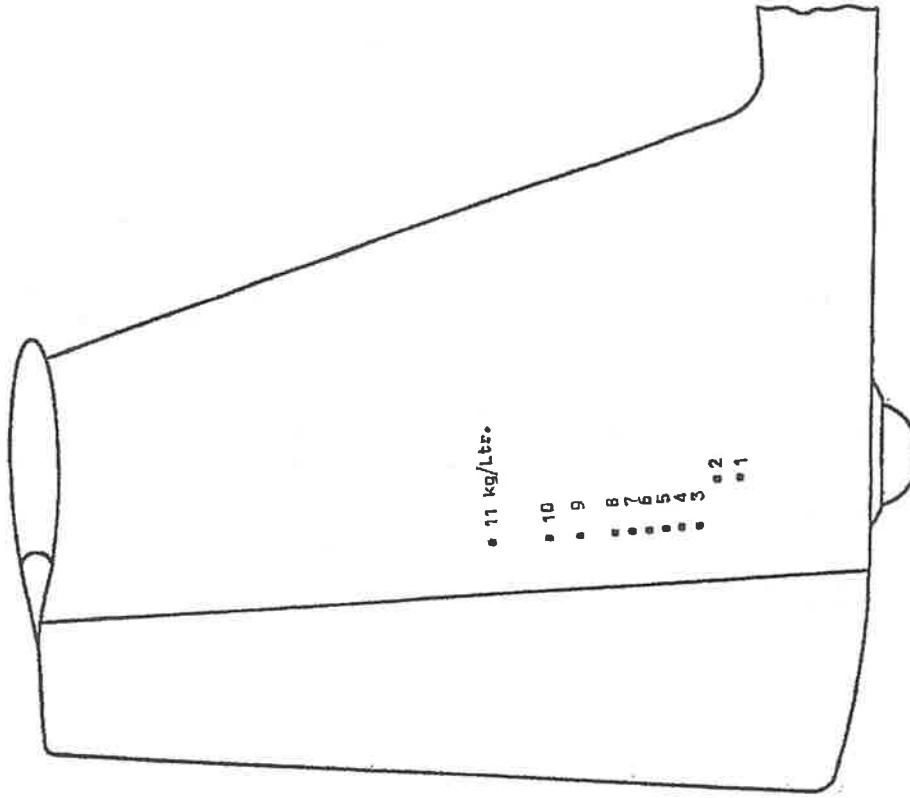

• 11 kg/Ltr.

• 10

• 9

• 8

• 7

• 6

• 5

• 4

• 3

• 2

• 1

Water is dumped from the fin tank through an opening on the lower side of the fuselage tail boom - adjacent to the rudder.

The fin tank dump valve is linked to the torsional drive for the valves on the main wing panels so that these three tanks are always emptying simultaneously.

The time required to dump the ballast from a full fin tank is about two (2) minutes, i.e. draining the full tanks of the main wing panels always takes longer.

ctd. on page 4.5.6.5

GENERALWARNING:

1. On longer flights at air temperatures near 0° C (32° F), water ballast must be dumped in any case when reaching a temperature of 2° C (36° F).

Caution:

2. There is little point in loading much water ballast if the average rate of climb expected does not exceed 1.0 m/s (197 fpm). The same applies to flights in narrow thermals requiring steep angles of bank.
3. If possible, all water ballast should be dumped before conducting an off-field landing.
4. Before the wing water tanks are filled, it should be checked (with dump valves unlocked) that both drain plugs open up equally. Leaking (dripping) valves are avoided by cleaning and greasing the plugs and their seats (with valves opened). Thereafter, with valves closed, the drain plugs are pulled home with the threaded tool used to attach the horizontal tailplane.

WARNING:

5. Never pressurize the tanks - for instance by filling them directly from a water hose - and always pour in clear water only.
6. On no account whatsoever must the "Duo Discus" ever be parked with full ballast tanks if there is the danger of them freezing up. Even in normal temperatures the parking period with full tanks should not exceed several days. For parking all water ballast is to be completely drained off with filler caps removed to allow the tanks to dry out.
7. Before the fin tank is filled, check that those spill holes not being taped closed are clear.

4.5.7 High altitude flight

When flying at high altitude it should be noted that true airspeed (TAS) increases versus indicated airspeed (IAS). This difference does not affect the structural integrity or load factors, but to avoid any risk of flutter, the following indicated values (IAS) must not be exceeded

| Altitude | | V (IAS) | | | Altitude | | V (IAS) | | |
|----------|-------|---------|-----|-----|----------|-------|---------|-----|-----|
| m | ft | km/h | kt | mph | m | ft | km/h | kt | mph |
| 0 | 0 | 250 | 135 | 155 | 6000 | 19685 | 205 | 111 | 127 |
| 1000 | 3281 | 250 | 135 | 155 | 7000 | 22966 | 194 | 105 | 121 |
| 2000 | 6562 | 250 | 135 | 155 | 8000 | 26247 | 183 | 99 | 114 |
| 3000 | 9843 | 241 | 130 | 150 | 9000 | 29528 | 172 | 93 | 107 |
| 4000 | 13123 | 229 | 124 | 142 | 10000 | 32808 | 162 | 87 | 101 |
| 5000 | 16404 | 217 | 117 | 135 | 12000 | 39370 | 141 | 76 | 88 |

Flying at temperatures below freezing point

When flying at temperatures below 0° C (32° F), as in wave or during the winter months, it is possible that the usual ease and smoothness of the control circuits is reduced.

It must therefore be ensured that all control elements are free from moisture so that there is no danger of them freezing solid. This applies especially to the airbrakes!

From experience gained to date it has been found beneficial to cover the mating surfaces of the airbrakes with "Vaseline" along their full length so that they cannot freeze solid. Furthermore the control surfaces should be moved frequently.

When flying with water ballast observe the instructions given in section 4.5.6.

Note:

The polyester coating on this sailplane is known from many years experience to become very brittle at low temperature.

Particularly when flying in wave at altitudes in excess of about 6000 m (approx. 20000 ft), where temperatures of below -30°C (-22°F) may occur, the gel-coat, depending on its thickness and the stressing of the sailplane's components, is prone to cracking!

Initially, cracks will only appear in the polyester coating, however, with time and changing environment, cracks can reach the Epoxy/glass matrix.

Cracking is obviously enhanced by steep descents from high altitudes at associated very low temperatures.

WARNING:

Therefore, for the preservation of a proper surface finish free from cracking, the manufacturer strongly advises against high altitude flights with associated temperatures of clearly below -20°C (-4°F)!

A steep descent with the airbrakes extended should only be conducted in case of emergency (instead of the airbrakes, the undercarriage may also be extended to increase the rate of sink).

4.5.8 Flight in rain

When flying the "Duo Discus" with a wet surface or in rain, the size of the water drops adhering to the wing causes a deterioration of its flight performance which cannot be expressed in numerical values due to the difficulties involved with such measurements. Often the air mass containing the moisture is also descending so that - compared with a wet sailplane in calm air - the sink rates encountered are higher.

Flight tests in rain, conducted by the manufacturer, did not reveal any significant differences in the stalling behaviour or stalling speeds.

It cannot be excluded, however, that excessive alterations of the airfoil (as caused by snow, ice or heavy rain) result in higher minimum speeds.

Approach in rain: See page 4.5.4.

4.5.9 Aerobatics

Aerobatic maneuvers are n o t permitted !

Section 5

- 5. Performance
- 5.1 Introduction
- 5.2 LBA-approved data
 - 5.2.1 Airspeed indicator system calibration
 - 5.2.2 Stall speeds
 - 5.2.3 (reserved)
 - 5.2.4 Additional information
- 5.3 Additional information -
LBA-approval not required
 - 5.3.1 Demonstrated crosswind performance
 - 5.3.2 Flight polar

5.1 Introduction

This section provides LBA-approved data for air-speed calibration, stall speeds and non-approved additional information.

The data in the charts has been computed from actual flight tests with a "Duo Discus" in good condition and using average piloting techniques.

5.2 LBA-approved data

5.2.1 Airspeed indicator system calibration

Errors in indicated airspeed (IAS) caused by Pitot/Static pressure errors may be read off from the calibration chart shown below.

PITOT pressure source: Fin

STATIC pressure ports: Fuselage tail boom, approx. 1.02 m (40.16 in.) forward of the base of the fin and 0.18 m (7.09 in.) below fuselage/wing fillet

All airspeeds shown in this manual are indicated airspeeds (IAS) as registered by the airspeed indicator.

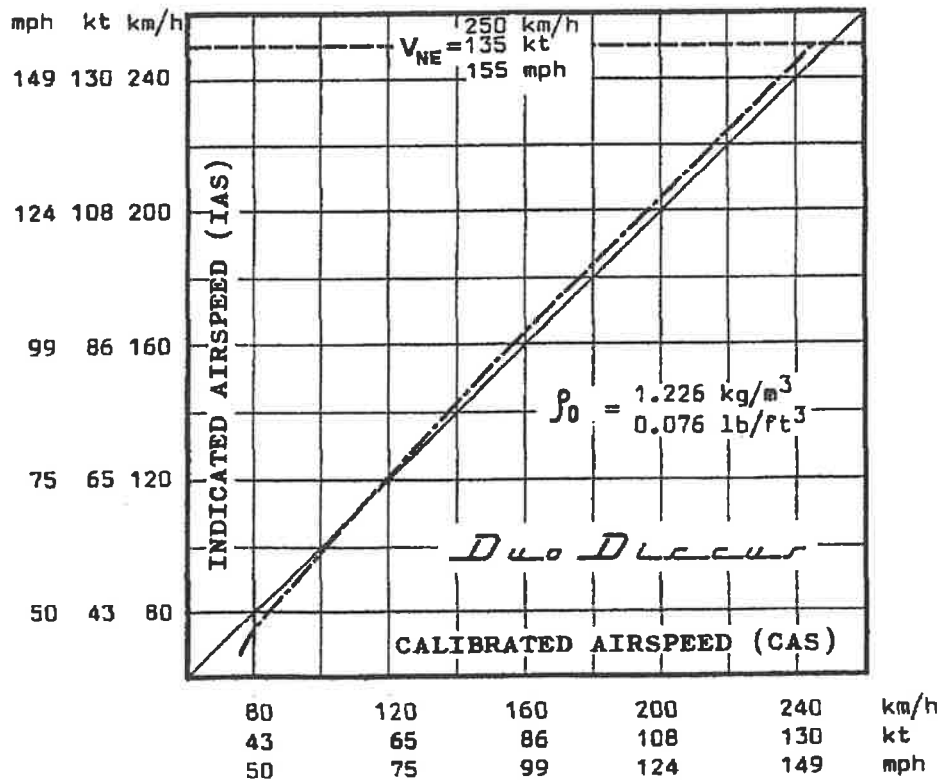

5.2.2 Stall speeds

The following stall speeds (IAS) were determined in straight and level flight:

| | | | |
|----------------------------------|-------------------|----------------------------------|----------------------------------|
| All-up mass approx. | kg lb | 499 1100 | 700 1543 |
| C/G position aft of datum | mm in. | 250 9.84 | 45 1.77 |
| Stall speed, airbrakes closed | km/h kt mph | 35 - 45* 19 - 24* 22 - 28* | 58 - 60* 31 - 32* 36 - 37* |
| airbrakes extended | km/h kt mph | 40 - 45* 22 - 24* 25 - 28* | 62 - 66* 33 - 36* 39 - 41* |

* At minimum speed the ASI reading is heavily oscillating because of turbulent air influencing the pitot tube in the fin

The loss of height from the beginning of the stall until regaining a normal level flight attitude is up to 30 m (98 ft).

5.2.3 - INTENTIONALLY LEFT BLANK -

Duo Discus

FLIGHT MANUAL

5.2.4 Additional information

N o n e

October 1993
Revision -

LBA-app.
5.2.4

5.3 Non-LBA-approved additional information

5.3.1 Demonstrated crosswind performance

The maximum crosswind velocity, at which take-offs and landings have been demonstrated, is

20 km/h (11 kt).

5.3.2 Flight polar

All values shown below refer to MSL

| | |
|----------------------|--|
| All-up mass | 609 kg 1343 lb |
| Wing loading | 37.1 kg/m ² 7.6 lb/ft ² |
| Minimum rate of sink | 0.58 m/s 114 fpm |
| Best L/D | 45 |
| at a speed of | 100 - 103 km/h 54 - 56 kt 62 - 64 mph |

Above values are extracted from a DLR/Idaflieg measurement in 1994.

For a speed polar diagram refer to page 5.3.2.2.

Duo Discus

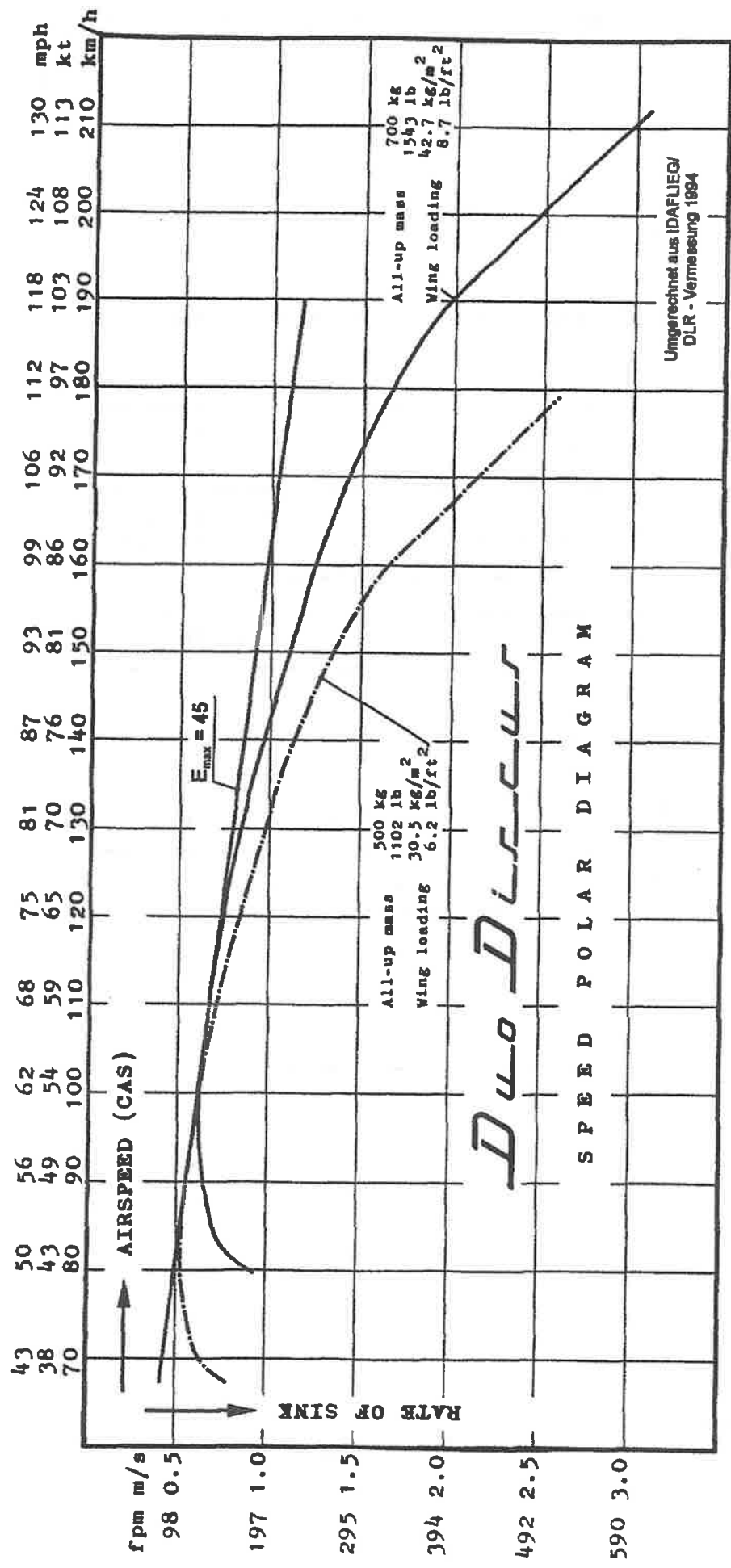

Section 6

6. Weight (mass) and balance

6.1 Introduction

6.2 Weight (mass) and balance record
and permitted payload range.

Determination of:

- Water ballast in wing tanks
- Water ballast in fin tank

6.1 Introduction

This section contains the seat load range within which the "Duo Discus" may be safely operated.

Procedures for weighing the sailplane and the calculation method for establishing the permitted payload range and a comprehensive list of all equipment available are contained in the "Duo Discus" Maintenance Manual.

The equipment actually installed during the last weighing of the sailplane is shown in the "Equipment List" to which page 6.2.3 refers to.

6.2 Weight and balance record / Permitted payload range

The following weight and balance log sheet (page 6.2.3) shows the maximum and minimum load on the seats. It is established with the aid of the last valid weighing report - the required data and diagrams are found in the "Duo Discus" Maintenance Manual.

The weight and balance log sheet is only applicable for this particular sailplane, the serial number of which is shown on the title page.

A front seat load of less than the required minimum is to be compensated by ballast - there are two methods:

1. By attaching ballast (lead or sand cushion) firmly to the lap belt mounting brackets.

Optional trim ballast mounting provision(s)

2. a) By installing ballast (by means of lead plates) at the base of the front instrument panel (for further information refer to page 6.2.2)
- b) By attaching ballast (in addition to method 2 a) by means of lead plates to the front control stick mounting frame on the starboard side near the base of the instrument panel (for further information refer to page 6.2.2).

Altering the front seat load by trim ballastOptional trim ballast mounting provision(s).

On request the "Duo Discus" is equipped with one or two mounting provisions for trim ballast, thus allowing a reduction of the placarded minimum front seat load (when flown solo) as shown in the table below.

- a) Trim ballast mounting provision below front instrument panel;

This tray holds up to three (3) lead plates with a weight of 3.7 kg/8.2 lb each. Plates are made to fit only into this tray.

Lever arm of trim ballast plates:

2055 mm (6.74 ft) ahead of datum

- b) Trim ballast mounting provision on front stick mounting frame on the starboard side;

This tray holds up to three (3) lead plates with a weight of 3.9 kg/8.6 lb each. Plates are made to fit only into this tray.

Lever arm of trim ballast plates:

1855 mm (6.09 ft) ahead of datum

| WHEN FLOWN SOLO: Difference in seat load as compared with placarded front seat minimum; | Number of lead plates required; |
|---|---------------------------------|
| up to 5 kg (11 lb) less | see a) |
| up to 10 kg (22 lb) less | |
| up to 15 kg (33 lb) less | |
| up to 20 kg (44 lb) less | see b) |
| up to 25 kg (55 lb) less | |
| up to 30 kg (66 lb) less | |

WEIGHT AND BALANCE LOG SHEET (loading chart)

for Ser.No.:

| | | | | |
|--|-----|-----|-----|-----|
| Date of weighing | | | | |
| Empty mass (kg) | | | | |
| Equipment list dated | | | | |
| Empty mass c/g position aft of datum (mm) | | | | |
| Max. useful load (kg) in fuselage incl. ballast in fin tank | | | | |
| Load (kg) on the seats (crew including parachutes): | | | | |
| Maximum front seat load when flown solo | 110 | 110 | 110 | 110 |
| with two occupants | | | | |
| Maximum rear seat load | | | | |
| Water ballast fin tank installed (YES / NO) | | | | |
| Minimum front seat load regardless of load on rear seat with | | | | |
| a) Fin tank NOT installed | | | | |
| b) Fin tank installed *) | | | | |
| Inspector Signature Stamp | | | | |

Note:

- *) 1. For safety reasons the value determined by weighing with an empty fin tank has been increased by 30 kg (66 lb) so as to allow for an unnoticed filled fin tank.
2. Adding the mass of 30 kg (66 lb) is not required, however, if the pilot either dumps all water ballast (prior to take-off) or does ensure that the ballast quantity in the fin tank is compensated by an appropriate load in the wing tanks and/or on the aft seat.

For the determination of the water ballast quantity permitted in the wing tanks refer to page 6.2.5.

For the determination of the water ballast quantity permitted in the fin tank refer to page 6.2.6 through 6.2.8.

SCHEMP-P-HIRTH FLUGZEUGBAU GMBH, KIRCHHEIM/TECK

Duo Discus

FLIGHT MANUAL

- INTENTIONALLY LEFT BLANK -

October 1993
Revision -

6.2.4

Duo Discus

Maximum water ballast load

Maximum all-up mass including water ballast : 700 kg (1543 lb)

C/G position of water ballast in wing tanks : 65 mm (2.56 in.) aft of datum plane

Note When determining the maximum permitted wing water ballast load, allowance must be made for water ballast in the fin tank (see page 6.2.7 and 6.2.8), i.e. this load must be added to the empty mass shown in the table below (if tank is used).

Empty mass * = Empty mass as per page 6.2.3 + ballast in fin tank

Tank capacity of both wing tanks : 198 kg/liter (52.31 US Gal., 43.56 IMP Gal.)

Table of water ballast loads at various empty masses and seat loads:

| Empty mass # | kg | | lb | | kg | | lb | | kg | | lb | | kg | | lb | | kg | | lb | | | | | | |
|--------------|-----|-------|--------|---------|-------|--------|---------|-------|--------|---------|-------|--------|---------|-------|--------|---------|-------|--------|---------|-------|--------|---------|-------|--------|---------|
| | 70 | 80 | 154 | 176 | 100 | 120 | 140 | 160 | 180 | 200 | 220 | 240 | 260 | 280 | 300 | 320 | 340 | 360 | 380 | 400 | | | | | |
| 410 | 904 | 198 | 52.3 | 43.6 | 190 | 50.2 | 41.8 | 170 | 44.9 | 37.4 | 150 | 39.6 | 33.0 | 130 | 34.3 | 28.6 | 110 | 29.1 | 24.2 | 90 | 23.8 | 19.8 | 70 | 18.5 | 15.4 |
| 420 | 926 | 198 | 52.3 | 43.6 | 180 | 47.6 | 39.6 | 160 | 42.3 | 35.2 | 140 | 37.0 | 30.8 | 120 | 31.7 | 26.4 | 100 | 26.4 | 22.0 | 80 | 21.1 | 17.6 | 60 | 15.9 | 13.2 |
| 430 | 948 | 198 | 52.3 | 43.6 | 170 | 44.9 | 37.4 | 150 | 39.6 | 33.0 | 130 | 34.3 | 28.6 | 110 | 29.1 | 24.2 | 90 | 23.8 | 19.8 | 70 | 18.5 | 15.4 | 50 | 13.2 | 11.0 |
| 440 | 970 | 190 | 50.2 | 41.8 | 180 | 47.6 | 39.6 | 160 | 42.3 | 35.2 | 140 | 37.0 | 30.8 | 120 | 31.7 | 26.4 | 100 | 26.4 | 22.0 | 80 | 21.1 | 17.6 | 60 | 15.9 | 13.2 |
| 450 | 992 | 180 | 47.6 | 39.6 | 170 | 44.9 | 37.4 | 150 | 39.6 | 33.0 | 130 | 34.3 | 28.6 | 110 | 29.1 | 24.2 | 90 | 23.8 | 19.8 | 70 | 18.5 | 15.4 | 50 | 13.2 | 11.0 |
| | | Liter | US Gal | IMP Gal | Liter | US Gal | IMP Gal | Liter | US Gal | IMP Gal | Liter | US Gal | IMP Gal | Liter | US Gal | IMP Gal | Liter | US Gal | IMP Gal | Liter | US Gal | IMP Gal | Liter | US Gal | IMP Gal |

Water ballast in wing tanks

Water ballast in (optional) fin tank

In order to shift the center of gravity close to its aft limit (favourable in terms of performance), water ballast may be carried in the fin tank (m_{FT}) to compensate for the nose-heavy moment of

- water ballast in main wing panels (m_{WT})
and/or
- loads on the aft seat (m_{P2})

Compensating water ballast in main wing panels

The determination of the ballast quantity in the fin tank (m_{FT}) is done with the aid of the diagram shown on page 6.2.8.

Compensating loads on the aft seat

Pilots wishing to fly with the center of gravity close to the aft limit, may compensate the nose-heavy moment of loads on the aft seat with the aid of the diagram shown on page 6.2.8.

Note: When using fin ballast to compensate for the nose-heavy moment of wing ballast and loads on the aft seat, then both values resulting from the diagrams on page 6.2.8 must be taken into account.

The maximum amount of water ballast, available for compensating the above mentioned nose-heavy moments, is 11 liter (2.91 US Gal., 2.42 IMP Gal), which is the maximum capacity of the fin tank.

WARNING:

A compensation of masses exceeding the placarded minimum front seat load is not allowed!

When determining the water ballast quantity for the fin tank, bear in mind that the maximum permitted useful load in the fuselage (see page 6.2.3 "Weight and balance log sheet") must not be exceeded - check as follows:

m_{P1} = load on front seat

m_{P2} = load on aft seat

m_{FT} = ballast in fin tank (to compensate for
ballast in wing tanks)

m_{FT*} = ballast in fin tank (to compensate for
loads on the aft seat)

$m_{P1} + m_{P2} + m_{FT} + m_{FT*}$ = less or equal to maximum
useful load in fuselage
(see also page 6.2.3)

In order to avoid that the maximum permitted all-up mass is exceeded, the ballast in the fin tank must also be taken into account when determining the maximum allowable ballast quantity for the wing tanks.

Lever arm of water ballast in fin tank (m_{FT}):

5320 mm (17.45 ft) aft of datum plane

Fin tank capacity: 11 kg/liter (2.91 US Gal., 2.42 IMP Gal.)

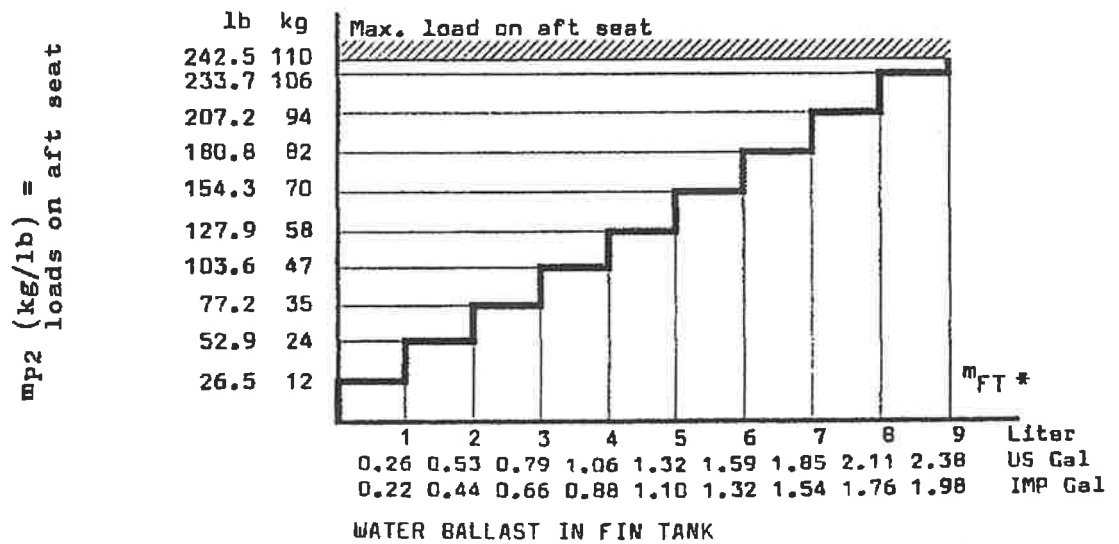
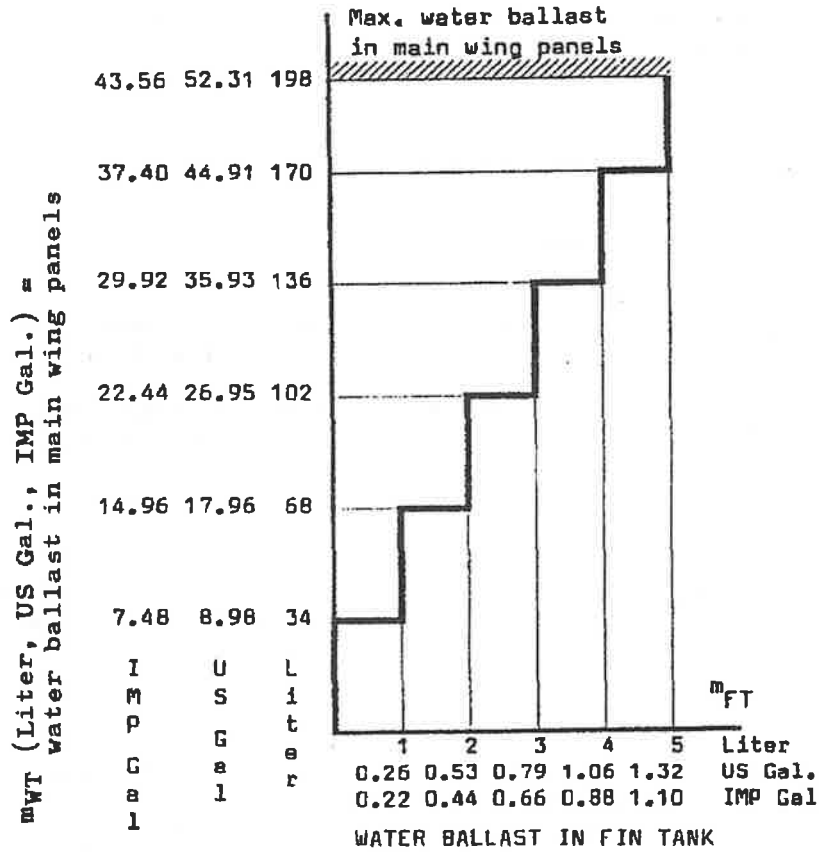

Section 7

- 7. Description of the sailplane and its systems
 - 7.1 Introduction
 - 7.2 Cockpit description
 - 7.3 Instrument panels
 - 7.4 Undercarriage
 - 7.5 Seats and restraint systems
 - 7.6 Static pressure and Pitot pressure system
 - 7.7 Airbrake system
 - 7.8 Baggage compartment
 - 7.9 Water ballast system
 - 7.10 (reserved)
 - 7.11 (reserved)
 - 7.12 Electrical system
 - 7.13 Miscellaneous equipment
(removable ballast, oxygen, ELT etc.)

7.1 Introduction

This section provides a description of the "Duo-Discus" including the operation of its systems.

For details concerning optional systems and equipment refer to section 9 "Supplements".

For further descriptions of components and systems refer to section 1 of the "Duo Discus" Maintenance Manual.

7.2 Cockpit description

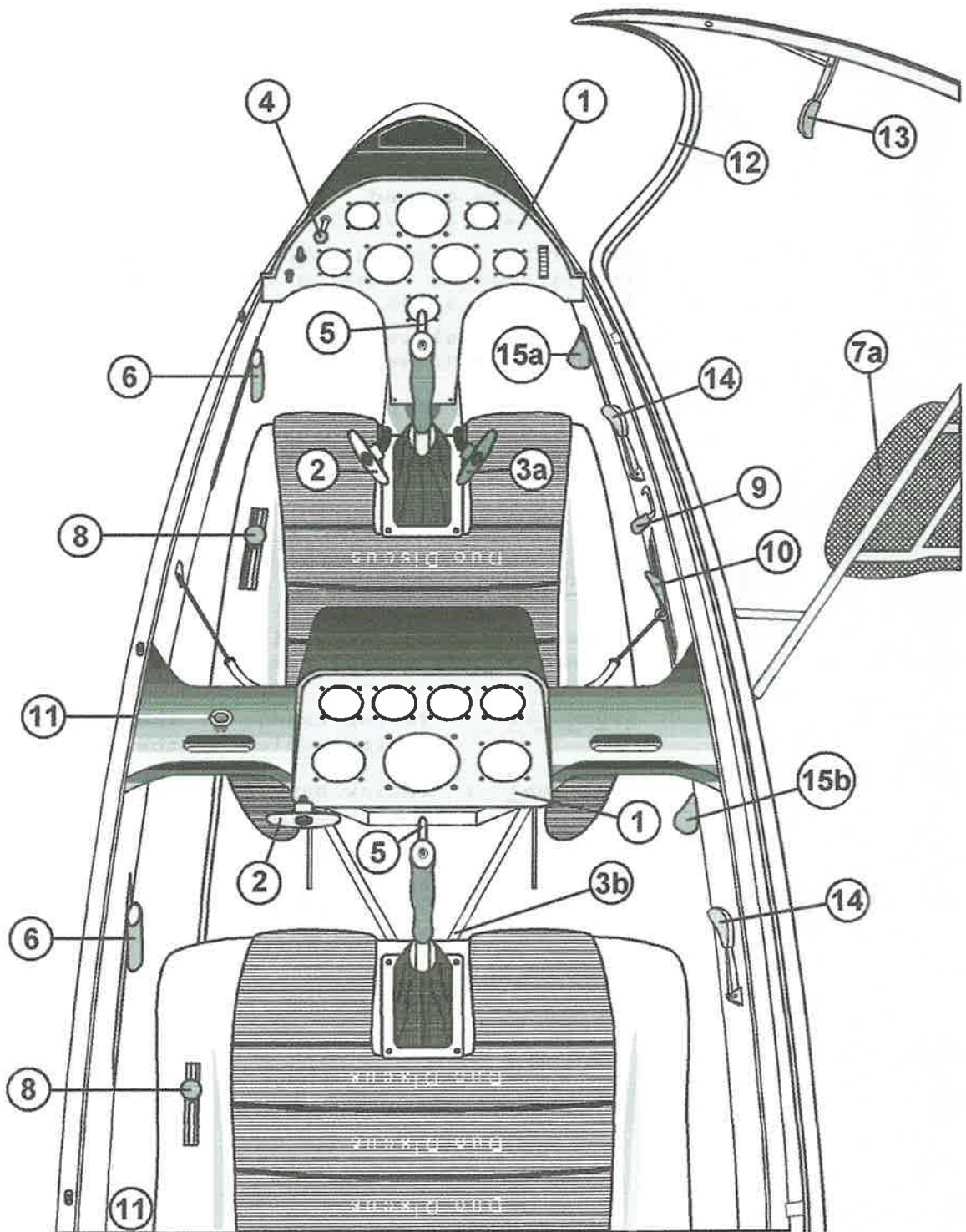

All instruments and control elements are within easy reach of the crew.

1

Instrument panels

With canopy opened, the instruments for either seat are easily accessible.

The front instrument panel is attached to the canopy coaming frame on the fuselage and to the control stick mounting frame.

The rear panel is mounted to the steel transverse frame between the seats.

Both instrument panels and their covers are easily detached after removing the mounting bolts.

2

Tow release handles

T-shaped handles, actuating the tow release(s) installed (c/g and/or nose hook)

Front seat : Yellow handle at the base of the control stick on the left

Rear seat : Yellow handle on the lower left hand side of the instrument panel

The winch cable/aerotow rope is released by pulling one of the handles.

3a

Rudder pedal adjustment (front seat)

Black T-shaped handle on the right near the base of the control stick.

Forward adjustment : Release locking device by pulling the handle, push pedals to desired position with the heels and let them engage.

Backward adjustment: Pull handle back until pedals have reached desired position. Forward pressure with heels (not the toes) engages pedals in nearest notch with an audible click.

An adjustment of the rudder pedals is possible on the ground and in the air.

3b

Rudder pedal adjustment (rear seat)

Locking device on pedal mounting structure on cockpit floor.

Forward or backward adjustment : Pull up locking pin by its ring, slide pedal assembly to desired forward or backward position and push locking pin down into nearest recess.

An adjustment of the rudder pedals is possible on the ground and in the air.

4

Ventilation

Small black knob on the front instrument panel on the left.

Pull to close ventilator

Push to open ventilator

Additionally the clear vision panels or the airscoop in the panels may be opened for ventilation.

5

Wheel brake

A wheel brake handle is mounted on either control stick.

Additionally the wheel brake can be actuated by extending the airbrakes fully.

6

Airbrake lever

Levers (with blue marking), projecting downwards, below the GFRP inner skin on the left.

Forward position : Airbrakes closed and locked

Pulled back about
40 mm (1.6 in.) : Airbrakes unlocked

Pulled fully back : Airbrakes fully extended and
wheel brake actuated

Head rests

7a

Front seat : Head rest (vertically adjustable)
on canopy transverse frame

7b

Rear seat (not
illustrated) : Mounting rail below upper fuse-
lage skin. Head rest is gradually
and horizontally adjustable;
Depress locking tap, slide head
rest in desired position and let
locking tap engage into nearest
recess

8

Elevator trim

Green knob (for either seat) at the seat pan mounting flange on the left.

The spring-operated elevator trim is gradually adjustable by swinging the green knob slightly inwards, sliding it to the desired position and swinging it outwards to lock.

| | | |
|-------------------|---|------------|
| Forward position | - | nose-heavy |
| Backward position | - | tail-heavy |

9

Control knob for dumping water ballast from wing tanks and (optional) fin tank

Black knob in the middle of the GFRP inner skin on the right.

| | | |
|-------------------|---|--------------------|
| Backward position | - | dump valves closed |
| Forward position | - | dump valves open |

The operating knob is locked in the extreme positions by swinging it downwards into a recess.

Fin tank (optional)

The fin tank dump valve control is connected to the torque tube actuating the valves on the wing so that all three valves open and close simultaneously.

10

Seat back (front seat)

Sliding black grip on the GFRP inner skin on the right.

Adjustment : Tilt front end of grip slightly inwards, slide grip to desired position and let engage by tilting it outwards.

11

Rip cord anchorage

Front seat : Red steel ring on tubular frame
between the seats on the left

Rear seat : Red steel ring at the front of
the steel tube center frame on
the left

12

Canopy

The one-piece plexiglass canopy hinges sideways on
flush fittings.

Take care that the cable restraining the open canopy
is properly hooked up.

13

Canopy locking and jettisoning levers

Lever with red grip for either seat on the canopy
frame on the left.

Forward position : Canopy locked

To open or jettison the canopy, swing one of the
levers back (beyond 90°) and raise canopy.

(14) Canopy release

Black lever (for front and rear seat) on the GFRP inner skin on the right.

To remove the canopy, proceed as follows:

Swing back the canopy release lever (approx. 90°) and the canopy locking lever, disconnect restraining cable and lift off the canopy.

Undercarriage

(15a) Front seat

Retracting : Disengage black handle below the GFRP inner skin on the right, pull it back and lock in rear recess

Extending: Disengage handle, push it forward and lock in front recess

(15b) Rear seat

Black handle below the GFRP inner skin on the right.

This handle is provided to assist in operating the undercarriage. It also indicates whether the wheel is up or down.

This handle cannot be used, however, to lock the undercarriage.

7.3.1 Instrument panels

front panel:

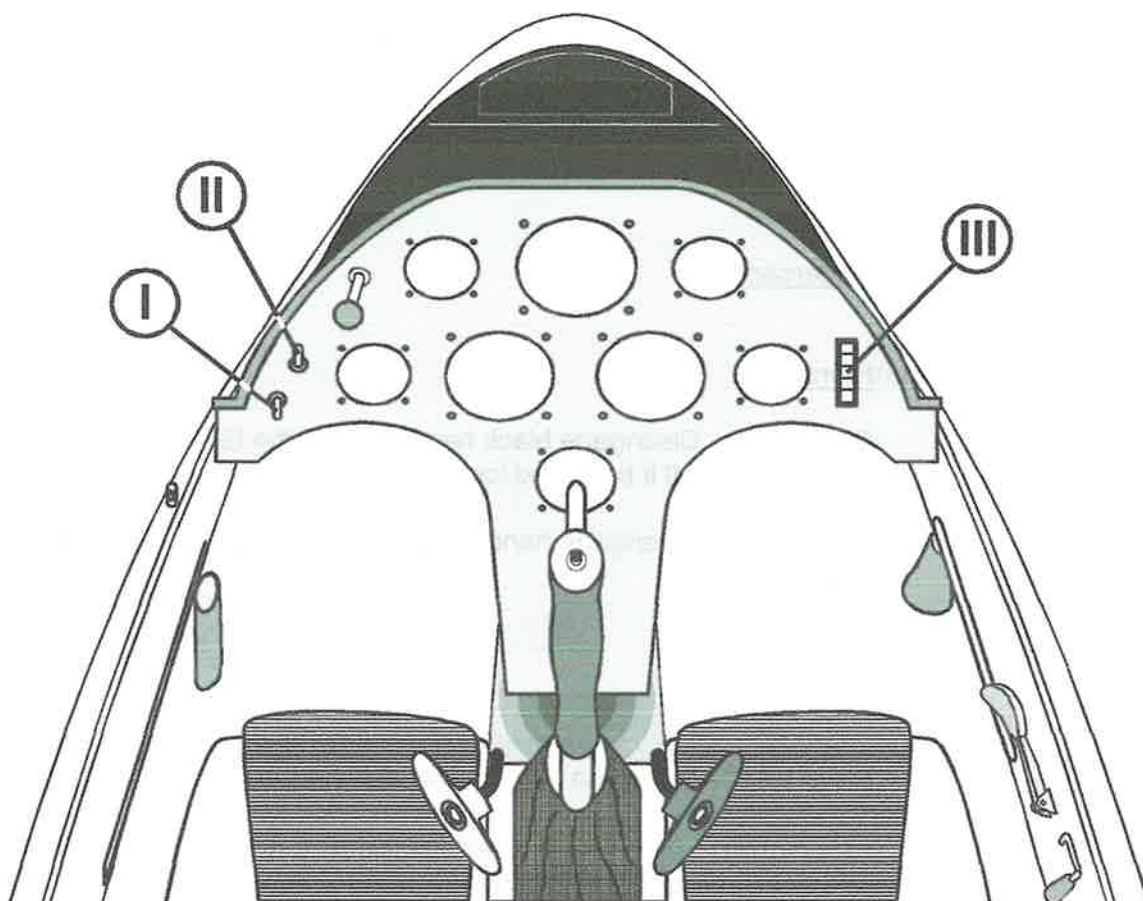

For a description of components No. I through III refer to the following page 7.3.2. A description of the instrumentation and an illustration of the rear instrument panel is not deemed necessary.

I

Master switch

Panel-mounted "ON/OFF" switch (for front seat).

UP = ON

DOWN = OFF

II

Pneumatic valve

Inapplicable

III

Outside air temperature indicator

7.4 Undercarriage

The main wheel of the "Duo Discus" is retractable and features a hydraulic disc brake. A small wheel is provided on the lower side of the forward fuselage section and protects the latter from damage. Instead of the standard rubber tail skid a non-steerable pneumatic wheel is available on request.

The extension/retraction process of the main wheel is described on page 7.2.4 ("cockpit description"), the operation of the main wheel brake is given on page 7.2.2 and 7.2.5.

For a technical description of the retractable undercarriage including its wheel brake system see also page 1.2.5 of the "Duo Discus" Maintenance Manual.

7.5 Seats and restraint systems

The seat pans are bolted to mounting flanges provided on either side of the cockpit.

The front seat features a back rest, adjustable in flight - see also page 7.2.5 concerning the procedure for its adjustment.

For either seat the lap straps are anchored to the seat pan.

While the shoulder straps for the front seat are anchored to the steel tube transverse frame, those for the rear seat are attached to the steel tube center frame.

A list of approved restraint systems is provided in chapter 7.1 of the "Duo Discus" Maintenance Manual.

7.6 Static pressure and Pitot pressure systemStatic pressure sources

- a) Static pressure ports are on either side of the fuselage tail boom, 1.02 m / 40.16 in. forward of the base of the fin (in the horizontal plane) and 0.18 m / 7.09 in. below the fuselage/wing-fillet, to be used for ASI etc.
- b) On request a special static pressure probe can be installed near the top of the fin (for further instruments, except ASI).
- c) On request additional static pressure sources can be provided on either side of the fuselage skin near the front instrument panel.

Pitot pressure source

The Pitot pressure head is situated near the upper end of the fin.

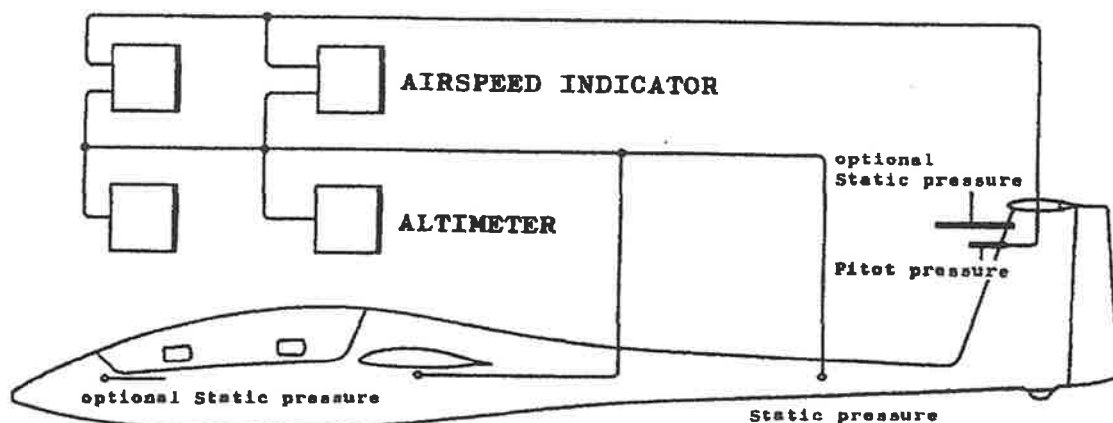

7.7 Airbrake system

Schempp-Hirth type airbrakes are employed on the upper surface of the main wing panels.

A schematic view of the airbrake system is given in the Maintenance Manual.

7.8 Baggage compartment

An enclosed baggage compartment is not provided.

Soft objects (like jackets etc.), however, may be deposited on the removable panel (covering the control linkages) behind the main spar stubs.

Such items, however, must be taken into account when determining the permissible load on the seats.

7.9 Water ballast system(s)

A steel cable connects the operating knob in the cockpit to a torque tube actuating the wing tank dump valves and - via a further steel cable - the dump valve of the (optional) fin tank - see page 7.9.3.

On rigging the main wing panels, the torque tube in the fuselage is automatically hooked up to the torsional drive of the dump valve plugs.

The torque tube is rotated to the "closed" position by spring force - see page 7.9.2.

The operating knob in the cockpit is run in a gate and can be locked in its extreme positions.

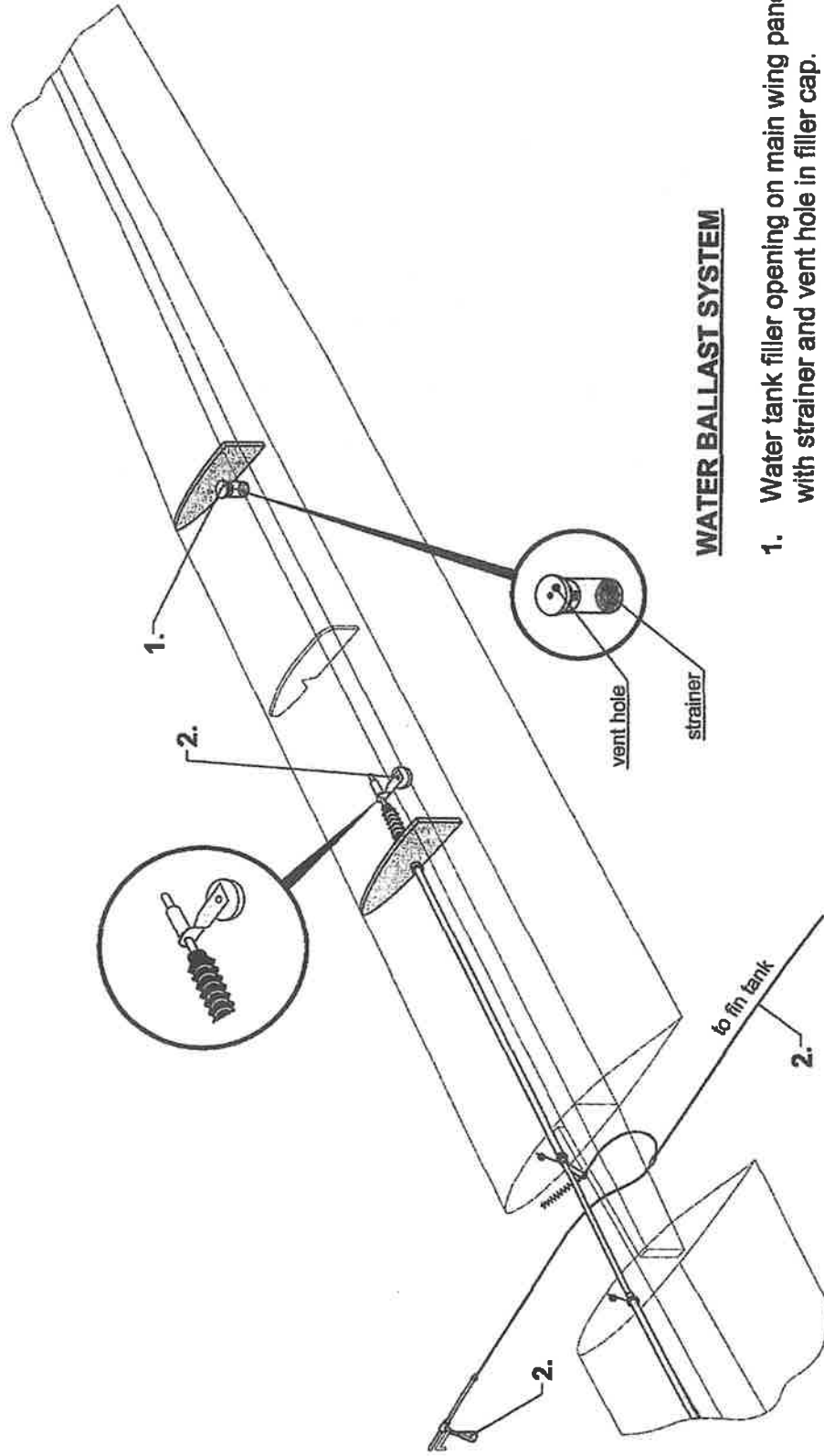

WATER BALLAST SYSTEM

1. Water tank filler opening on main wing panels with strainer and vent hole in filler cap.
2. Dump valve control for wing tanks and fin tank.

Duo Discus

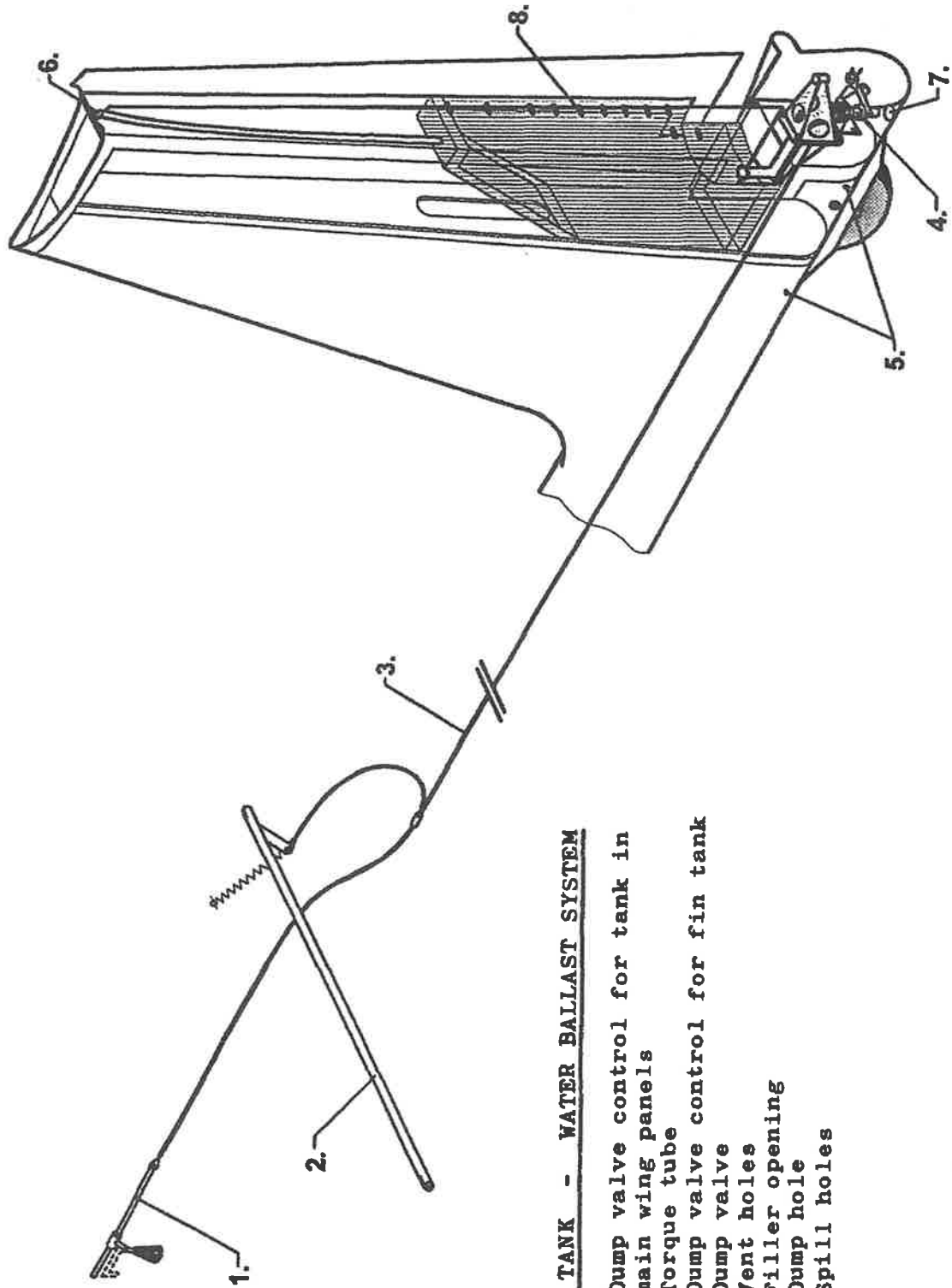

FIN TANK - WATER BALLAST SYSTEM

- 1. Dump valve control for tank in main wing panels
- 2. Torque tube
- 3. Dump valve control for fin tank
- 4. Dump valve
- 5. Vent holes
- 6. Filler opening
- 7. Dump hole
- 8. Spill holes

7.10 - INTENTIONALLY LEFT BLANK -

7.11 - INTENTIONALLY LEFT BLANK -

7.12 Electrical system

Gliding avionics - see wiring diagram on page 7.12.2

The wiring of the gliding avionics is shown on the next page and must comply with the manufacturer's instructions for the relevant equipment.

Power to operate the avionics is provided by one or more batteries located forward of the rear control stick mounting frame or next to the fuselage steel tube center frame.

A master switch controls the power source(s).

Duo Discus

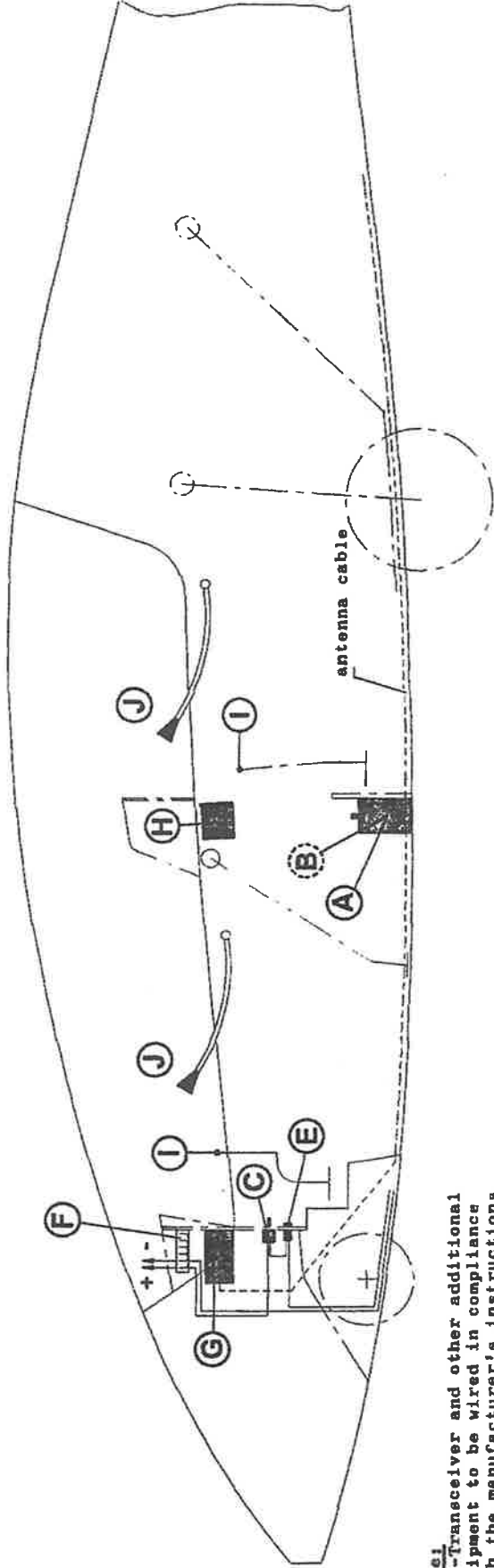

Note:
VHF-Transceiver and other additional equipment to be wired in compliance with the manufacturer's instructions and to be fused individually.

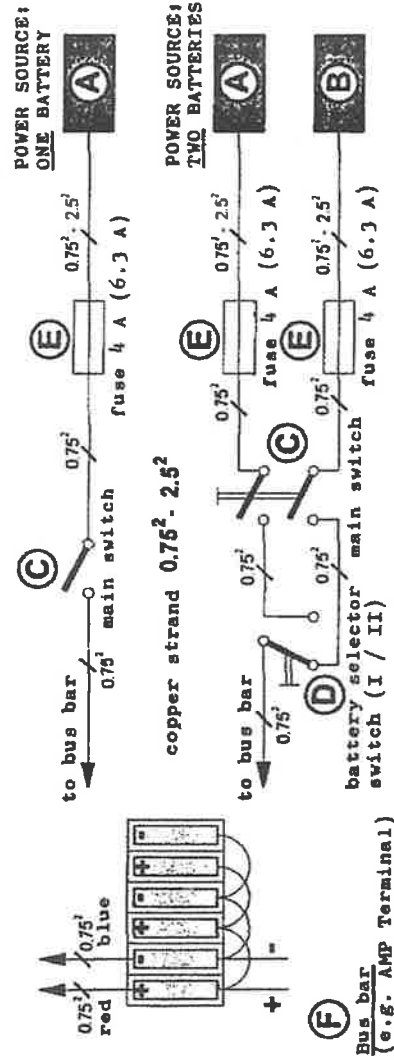

- (A) Battery I (12 V / 6.5 Ah)
- (B) Battery II (12 V / 6.5 Ah)
- (C) Main switch
- (D) Battery selector switch
- (E) Fuse 4 A (6.3 A)
- (F) Bus bar (e.g. AMP Terminal)
- (G) VHF-Transceiver
- (H) Speaker
- (I) PTT button
- (J) Boom microphone

ELECTRICAL SYSTEM - AVIONICS
S14 RE 811

7.13 Miscellaneous equipment

Removable ballast (optional)

A mounting provision for removable ballast (trim ballast weights) is provided at the base of the front instrument panel.

A second ballast mounting provision is found on the right hand side of the front stick mounting frame.

The trim ballast weights (lead plates) are to be secured in place by bolts.

For information on how to alter the minimum front seat load refer to section 6.2.

Oxygen systems

Attachment points for the mounting brackets of oxygen bottles are provided on the rear wing suspension tube (for the neck) and further aft on the horizontal GFRP-reinforcement (for the cylinder).

For the installation of oxygen systems, drawings may be obtained from the manufacturer.

Note: After oxygen systems are installed, it is necessary to re-establish the empty mass c/g position of the "Duo Discus" concerned to ensure that the center of gravity is still within the permitted range.

A list of oxygen regulators, currently approved by the Luftfahrt Bundesamt (LBA), is found in the "Duo Discus" Maintenance Manual.

ELT-installation

The installation of an Emergency Locator Transmitter is possible in the following places and must comply with the instructions provided by Schempp-Hirth:

- In the region of the rear seat
on either seat pan mounting flange
- On top of the main wheel housing
- At the bottom of the O₂-cylinder mount

Section 8

- 8. Sailplane handling, care and maintenance
 - 8.1 Introduction
 - 8.2 Sailplane inspection periods
 - 8.3 Sailplane alterations or repairs
 - 8.4 Ground handling / road transport
 - 8.5 Cleaning and care

8.1 Introduction

This section contains manufacturer's recommended procedures for proper ground handling and servicing of the sailplane.

It also identifies certain inspection and maintenance requirements which must be followed if the sailplane is to retain that "new plane" performance and dependability.

CAUTION:

It is wise to follow a planned schedule of lubrication and preventative maintenance based on climate and flying conditions encountered - see section 3.2 of the "Duo Discus" Maintenance Manual.

8.2 Sailplane inspection periods

For details concerning the maintenance of this sailplane refer to its Maintenance Manual.

Airframe maintenance

Under normal operating conditions no airframe maintenance work is required between the annual surveys, except for the routine greasing of the spigots and ball bearings of the wing and tailplane attachment fittings.

Should the control system become heavy to operate, lubricate those places in the fuselage and in the wing panels where plain bearings are used (e.g. air-brake linkage).

Cleaning and greasing the wheels and the tow release(s) depends on the accumulation of dirt.

Rudder cables

After every 200 flying hours and at every annual survey, the rudder cables are to be inspected at the point where they feed through the S-shaped guides in the pedals, especially at the point of maximum pedal adjustment.

If the rudder cables are damaged, worn or corroded, they must be replaced.

It is permissible for individual strands of the cables to be worn up to 25 %.

8.3 Alterations or repairs

Alterations

Alterations on the approved model, which might affect its airworthiness, must be reported to the responsible airworthiness authorities *p r i o r* to their accomplishment.

The authorities will then determine whether and to what extent a "supplemental type approval" is to be conducted.

In any case, the manufacturer's opinion about the alteration(s) must be obtained.

This ensures that the airworthiness does not become adversely affected and/or enables the aircraft owner/ operator to demonstrate at any time that the powered sailplane concerned complies with an LBA-approved version.

Amendments of the LBA-approved sections of the Flight- and/or Maintenance Manual must in any case be approved by the Luftfahrt Bundesamt (LBA).

Repairs

Abbreviations:

CFRP: carbon-fibre reinforced plastic

GFRP: glas-fibre reinforced plastic

Before every take-off and especially after the powered sailplane has not been used for a while, it should be checked on the ground as shown in section 4.3.

Check for any sign of a change in the condition of the aircraft, such as cracks in the surface, holes, delamination in the CFRP/GFRP structure etc.

If there is any uncertainty whatsoever regarding the significance of damage discovered, the "Duo Discus T" should always be inspected by a CFRP/GFRP expert.

There is no objection to minor damage - which does not affect the airworthiness in any way - being repaired on site.

A definition of such damage is included in the "REPAIR INSTRUCTIONS" which are found in the appendix to the "Duo Discus T" Maintenance Manual.

Major repairs may only be conducted by a certified repair station having an appropriate authorization.

8.4 Ground handling / road transporta) Towing/Pushing

When towing the "Duo Discus" behind a car, a tail dolly should always be used to avoid unnecessary tailplane vibration on the fittings - especially in tight turns.

When pushing the sailplane by hand, it should not be pushed at its wing tips, but as near to the fuselage as possible.

b) Hangaring

The "Duo Discus" should always be hangared or kept in well ventilated conditions. If it is kept in a closed trailer, there must be adequate ventilation.

The water ballast tanks must always be left completely empty.

The sailplane must never be subjected to loads whilst not in use, especially in the case of high ambient temperatures.

c) Tie-down

In the case of a "Duo Discus" remaining rigged permanently, it is important that the maintenance program includes rust prevention for the fittings on fuselage, wings and tailplane.

Tie-down kits common in trade may be used to anchor the sailplane.

Dust covers should be regarded as essential for the "Duo Discus".

d) Preparing for road transport

As the wings have a thin airfoil section, it is important that they are properly supported, i.e. leading edge down, with support at the spar stubs and at the outer portion in cradles of correct airfoil section.

The fuselage can rest on a broad cradle just forward of the u/c doors and on its tail wheel/skid. The horizontal tailplane should be kept leading edge down in two cradles of correct airfoil section or placed horizontally on a padded support.

On no account should the tailplane be supported by its fittings in the trailer.

8.5 Cleaning and care

Although the surface coating of a composite sailplane is robust and resistant, always take care of a perfect surface.

For cleaning and caring the following is recommended:

- Clean the surface (especially the leading edge of the wings, horizontal stabilizer and fin) with clear water, a sponge and a chamois leather.
- Do not use too often rinsing additives common in trade.
- Polish and polishing materials may be used.
- Petrol and alcohol may be used momentarily only, thinners of all kinds are not recommended.
- Never use chlorine hydrogen (i.e. Tri, Tetra, Per etc.).
- The best polishing method is the buffing of the surface by means of an edge buffing wheel, fitted to a drilling or polishing machine.

Thereby hard wax is applied to the rotating disc and distributed crosswise over the surface.

WARNING:

To avoid a local overheating, the buffing wheel should be moved constantly!

- The canopy should be cleaned with a plexiglass cleaner (e.g. "Plexiklar", "Mirror Glaze" or similar) and only if necessary, with warm water. The canopy should be wiped down only with a soft clean chamois leather or a very soft material as used for gloves.
Never rub the canopy when it is dry!
- The "Duo Discus" should always be protected from the wet. If water has found a way in, the components should be stored in a dry environment and turned frequently to eliminate the water.
- The "Duo Discus" should not be exposed unnecessarily to intense sunlight or heat and should not be subjected to continual loads in a mechanical sense.

WARNING:

All external portions of the sailplane exposed to sunlight must be painted white - with the exception of the areas for the registration and anti-collision markings.

Colours other than white can lead to the GFRP/CFRP overheating in direct sunlight, resulting in an insufficient strength.

Section 9

- 9. Supplements**
- 9.1 Introduction**
- 9.2 List of inserted supplements**

Duo Discus

9.1 Introduction

This section contains the appropriate supplements necessary to safely and efficiently operate the sailplane when equipped with various optional systems and equipment not provided with the standard aircraft.

9.2 List of inserted supplements

| Date | Section | Title of inserted supplement |
|------|---------|------------------------------|
| | | |

